

Please read and save these instructions. Read through this owner's manual carefully before using product. Protect yourself and others by observing all safety information, warnings, and cautions. Failure to comply with instructions could result in personal injury and/or damage to product or property. Please retain instructions for future reference

1. General Safety Information

1.1 Your Welding Environment

- Keep the environment you will be welding in free from flammable materials.
- Always keep a fire extinguisher accessible to your welding environment.
- Always have a qualified person install and operate this equipment.
- Make sure the area is clean, dry and ventilated. Do not operate the welder in humid, wet or poorly ventilated areas.
- Always have your welder maintained by a qualified technician in accordance with local, state and national codes.
- Always be aware of your work environment. Be sure to keep other people, especially children, away from you while welding.
- Keep harmful arc rays shielded from the view of others.
- Mount the welder on a secure bench or cart that will keep the welder secure prevent it from tipping over or falling.

1.2 Your Welder's Condition

- Check all cables, power cord and TIG Torch to be sure the insulation is not damaged. Always replace or repair damaged components before using the welder.
- Check all components to ensure they are clean and in good operating condition before use.

1.3 Use of Your Welder

▲ CAUTION

- Do not operate the welder if the welding cables, electrode, TIG torch is wet. Do not immerse them in water. These components and the welder must be completely dry before attempting to use them.
- Follow the instructions in this manual.
 - Keep welder in the off position when not in use.
 - Connect ground lead as close to the area being welded as possible to ensure a good ground.
 - Do not allow any body part to come in contact with the TIG torch if you are in contact with the material being welded, ground or electrode from another welder.
 - Do not weld if you are in an awkward position. Always have a secure stance while welding to prevent accidents. Wear a safety harness if working above ground.
 - Do not drape cables over or around your body.
 - Wear a full coverage helmet with appropriate shade (see ANSI Z87.1 safety standard) and safety glasses while welding.
-

- Wear proper gloves and protective clothing to prevent your skin from being exposed to hot metals, UV and IR rays.
- Do not overuse or overheat your welder. Allow proper cooling time between duty cycles.
- Keep hands and fingers away from moving parts.
- Do not point TIG torch at any body part of yourself or anyone else.
- Always use this welder in the rated duty cycle to prevent excessive heat and failure.

1.4 Specific Areas of Danger, Caution or Warning

Electrical Shock



▲ WARNING

Electric arc welders can produce a shock that can cause injury or death. Touching electrically live parts can cause fatal shocks and severe burns. While welding, all metal components connected to the TIG torch are electrically hot. Poor ground connections are a hazard, so secure the ground lead before welding.

- Wear dry protective apparel: coat, shirt, gloves and insulated footwear.
- Insulate yourself from the work piece. Avoid contacting the work piece or ground.
- Do not attempt to repair or maintain the welder while the power is on.
- Inspect all cables and cords for any exposed wire and replace immediately.
- Use only recommended replacement cables and cords.
- Always attach ground clamp to the work piece or work table as close to the weld area as possible.
- Do not touch the TIG Torch and the ground or grounded work piece at the same time.
- Do not use a welder to thaw frozen pipes.

Fumes and Gases



▲ WARNING

- Fumes emitted from the welding process displace clean air and can result in injury or death.
- Do not breathe in fumes emitted by the welding process. Make sure the air you breath is clean and safe.
- Work only in a well-ventilated area or use a ventilation device to remove welding fumes from the environment where you will be working.
- Do not weld on coated materials (galvanized, cadmium plated or containing zinc, mercury or barium). They will emit harmful fumes that are dangerous to breathe. If necessary use a ventilator, respirator with air supply or remove the coating from the material in the weld area.
- The fumes emitted from some metals when heated are extremely toxic. Refer to the material safety data sheet for the manufacturer's instructions.
- Do not weld near materials that will emit toxic fumes when heated. Vapors from cleaners, sprays and degreasers can be highly toxic when heated.



UV and IR Arc Rays

⚠ DANGER

The welding arc produces ultraviolet (UV) and infrared (IR) rays that can cause injury to your eyes and skin. Do not look at the welding arc without proper eye protection.

- Always use a helmet that covers your full face from the neck to top of head and to the back of each ear.
- Use a lens that meets ANSI standards and safety glasses. For welders under 200 Amps output, use a shade 10 lens; for above 200 Amps, use a shade 12. Refer to the ANSI standard Z87.1 for more information.
- Cover all bare skin areas exposed to the arc with protective clothing and shoes. Flame-retardant cloth or leather shirts, coats, pants or coveralls are available for protection.
- Use screens or other barriers to protect other people from the arc rays emitted from your welding.
- Warn people in your welding area when you are going to strike an arc so they can protect themselves.



Fire Hazards

⚠ WARNING

- Do not weld on containers or pipes that contain or have had flammable, gaseous or liquid combustibles in them. Welding creates sparks and heat that can ignite flammable and explosive materials.
- Do not operate any electric arc welder in areas where flammable or explosive materials are present.
 - Remove all flammable materials within 35 feet of the welding arc. If removal is not possible, tightly cover them with fireproof covers.
 - Take precautions to ensure that flying sparks do not cause fires or explosions in hidden areas, cracks or areas you cannot see.
 - Keep a fire extinguisher close in the case of fire.
 - Wear garments that are oil-free with no pockets or cuffs that will collect sparks.
 - Do not have on your person any items that are combustible, such as lighters or matches.
 - Keep work lead connected as close to the weld area as possible to prevent any unknown, unintended paths of electrical current from causing electrical shock and fire hazards.
 - To prevent any unintended arcs, do not place TIG torch on grounded work surface.



Hot Materials

⚠ CAUTION

Welded materials are hot and can cause severe burns if handled improperly.

- Do not touch welded materials with bare hands.
- Do not touch TIG torch or electrode after welding until it has had time to cool down.



Sparks/Flying Debris

▲ CAUTION

Welding creates hot sparks that can cause injury. Chipping slag off welds creates flying debris.

- Wear protective apparel at all times: ANSI-approved safety glasses or shield, welder's hat and ear plugs to keep sparks out of ears and hair.



Electromagnetic Field

▲ CAUTION

-Electromagnetic fields can interfere with various electrical and electronic devices such as pacemakers.

-Consult your doctor before using any electric arc welder or cutting device

- Keep people with pacemakers away from your welding area when welding.
- Do not wrap cable around your body while welding.
- Wrap TIG torch and ground cable together whenever possible.
- Keep TIG torch and ground cables on the same side of your body.



Shielding Gas Cylinders Can Explode

▲ WARNING

High pressure cylinders can explode if damaged, so treat them carefully

- Never expose cylinders to high heat, sparks, open flames, mechanical shocks or arcs
- Do not touch cylinder with TIG torch
- Do not weld on the cylinder.
- Always secure cylinder upright to a cart or stationary object.
- Keep cylinders away from welding or electrical circuits.
- Use the proper regulators, gas hose and fittings for the specific application.
- Do not look into the valve when opening it.
- Use protective cylinder cap whenever possible.

1.5 Proper Care, Maintenance and Repair

▲ DANGER

- Always have power disconnected when working on internal components.
- Do not touch or handle PC board without being properly grounded with a wrist strap. Put PC board in static proof bag to move or ship.
- Do not put hands or fingers near moving parts such as the cooling fan

Air Cooled TIG Torch

2. Description

The Air Cooled TIG torch is designed to operate with the MIG/Stick 140, MIG/Stick 200 or Hybrid MIG/Stick 200 welder for DC lift start TIG welding on steels or stainless steels. This torch may also be used on other TIG welding units with twist lock style weld terminals.











The Air Cooled TIG torch is rated at 150A at 35% duty cycle. This torch is ideal for light fabrication, welding repair and maintenance operations.

3. Specifications and Dimension

DESCRIPTION	SPECIFICATIONS
Amperage	150A
Cooling Method	Air-Cooled
Duty cycle	35%
Suggested Tungsten Sizes	.020 in. to 1/16 in.
Cable Length	9 ft.
Net Weight	3 lbs.

4. Assembly & Set-Up

1.		<p>Remove Ground Cable and install in the electrode holder connection. This sets up the TIG torch for DC Electrode Negative which is needed for DC TIG welding of steels and stainless steels.</p>
2.		<p>Secure the ground clamp to the surface you are welding.</p>
3.		<p>Connect your regulator and gas hose to the bottle of shielding gas. Typically 100% argon is used for most TIG applications. Connect the TIG torch gas connection to the regulator.</p>
4.		<p>Connect the TIG torch to the Ground Cable connection. This sets up the TIG torch for DC Electrode Negative which is needed for DC TIG welding of steels and stainless steels.</p>
5.		<p>Flip the process selector switch into the stick mode. This puts the machine into the constant current mode needed for TIG welding.</p> <p>⚠ CAUTION</p> <p>Be aware that the TIG torch is now electrically hot. Keep TIG torch away from the grounded work surface until ready to weld.</p>
6.		<p>Set Amperage on the front of the welder</p>
7.		<p>Turn on the input power switch on your welder.</p> <p>⚠ CAUTION</p> <p>Be aware that the TIG torch is now electrically hot. Keep TIG torch away from the grounded work surface until ready to weld.</p>

8.		Turn the TIG Torch gas valve clockwise to start the flow of shielding gas. After welding, turn the TIG torch gas valve counter-clockwise to turn off the flow of shielding gas.
9.		Touch tungsten to work piece and lift away to start arc.

5. Spare Parts List

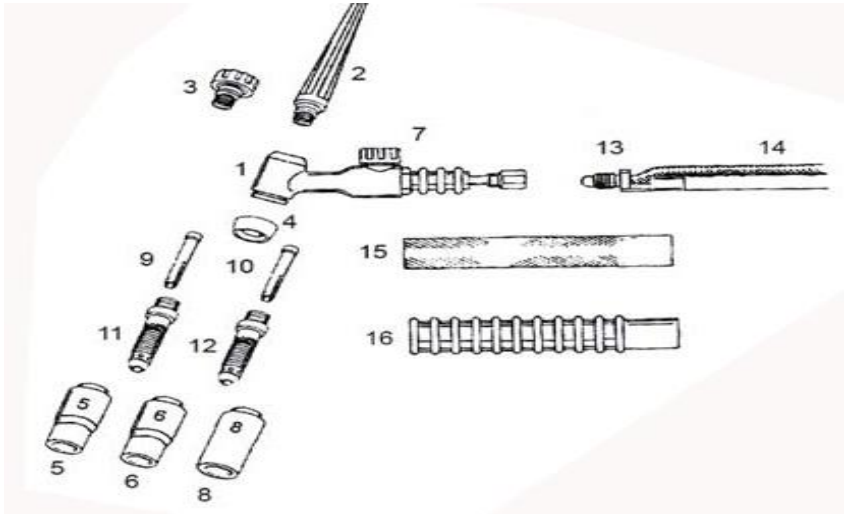

Reference number	Description	Qty
1	Plastic cap	1
2	Long cap	1
3	Short cap	1
4	White cap	1
5	Nozzle 4# (ϕ 6.5)	1
6	Nozzle 5# (ϕ 8.0)	1
7	Switch	1
8	Nozzle 6# (ϕ 9.5)	1
9	Tungsten needle ϕ 1.6	1
10	Tungsten needle ϕ 1.0、 ϕ 2.4	Per 1
11	Diversion ϕ 3.2	1
12	Diversion ϕ 2.4	1

13	Screw	1
14	Cable (16mm ²)	1
15	Handle cover	1
16	Copper	1

17	Cable cover	1
18	Gas connector	1
19	Gas hose (φ6)	1
20	Clip (SK 10-25)	1



Other Safety and Standards Information

This manual is designed to inform the operator of safety and general use of this model only. For further information about welding safety refer to the following standards and comply with them where applicable.

• **ANSI Standard Z49.1** — SAFETY IN WELDING AND CUTTING obtainable from: American Welding Society 550 NW Le Jeune Road, Miami, FL 33126
Tel. (800) 443-9353 Fax (305) 443-7559
www.amweld.org or www.aws.org

• **ANSI Standard Z87.1** — SAFE PRACTICE FOR OCCUPATION AND EDUCATIONAL EYE AND FACE PROTECTION

Obtainable from: American National Standards Institute (ANSI) 11 West 42nd St. New York, NY 10036
Tel. (212) 642-4900 Fax (212) 398-0023 www.ansi.org

• **NFPA Standard 51B** — CUTTING AND WELDING PROCESS obtainable from: National Fire Protection Association, 1 Batterymarch Park, P.O. Box 9101 Quincy, MA 02269-9101
Tel. (617) 770-3000 Fax (617) 770-0700 www.nfpa.org

• **OSHA Standard 29 CFR**, Part 1910, Subpart Q. —WELDING, CUTTING AND BRAZING obtainable from your state OSHA office or from: U. S. Dept. of Labor OSHA, Office of Public Affairs Room N3647, 200 Constitution Ave. NW Washington, DC 20210 www.osha.gov

• **CSA Standard W117.2** — Code for SAFETY IN WELDING AND CUTTING Obtainable from: Canadian Standards Association, 178 Rexdale Blvd., Etobicoke, Ontario M9W 1R3
www.csa.ca

• **American Welding Society Standard A6.0** —WELDING AND CUTTING CONTAINERS WHICH HAVE HELD COMBUSTIBLES Obtainable from: American Welding Society, 550 NW Le Jeune Road Miami, FL 33126
Tel. (800) 443-9353
Fax (305) 443-7559
www.amweld.org or www.aws.org
