



# M190

Item# 9002180

## OPERATOR'S MANUAL



**Read carefully and understand RULES FOR SAFE OPERATION and instructions before operating. Failure to follow the safety rules and other basic safety precautions may result in serious personal injury.**

# TABLE OF CONTENTS

<b>Warranty</b> .....	2	Install the Welding Wire .....	14
<b>Safety Summary</b> .....	3	Set the Wire Drive Tension .....	15
Safety Information.....	3	Change Polarity .....	16
Shock Hazards .....	4	<b>Operation</b> .....	17
Flash Hazards.....	4	Controls and Indicators.....	17
Fire Hazards .....	5	Power Switch .....	17
Fume Hazards .....	6	Voltage Selector .....	17
Compressed Gasses		Wire Speed Control .....	17
and Equipment Hazards.....	6	Tuning in the Wire Speed.....	17
Additional Safety Information .....	7	Learning to Weld.....	18
<b>Welder Specifications</b> .....	8	Holding the Torch .....	18
Description .....	8	Welding Techniques .....	19
Welder Operating Characteristics.....	8	Moving the Torch .....	19
Duty Cycle .....	8	Types of Weld Beads .....	19
Internal Thermal Protection .....	8	Welding Positions.....	20
<b>Know Your Welder</b> .....	9	Multiple Pass Welding .....	21
<b>Welder Installation</b> .....	10	Special Welding Methods.....	22
Power Source Connection .....	10	Spot Welding .....	22
Power Requirements .....	10	<b>Maintenance</b> .....	23
Connect to Power Source .....	10	General .....	23
Extension Cords.....	10	Consumable Maintenance .....	23
Assembling the Welder.....	10	Maintaining the Contact Tip .....	23
Unpacking the Welder .....	10	Maintaining the Nozzle .....	23
Packing List .....	10	Testing for a Shorted Nozzle .....	24
Assemble the Face Shield .....	10	Replace a Torch Liner.....	24
Installing the Handle.....	11	Preventive Maintenance .....	25
Selecting Shielding Gas .....	11	Troubleshooting .....	25
Install the Shielding Gas .....	12	<b>Parts List</b> .....	28
Check the Gas Flow .....	12	<b>Wiring Diagram</b> .....	29
Align and Set the Drive Roller .....	12	<b>Suggested Settings</b> .....	30
Selecting the Welding Wire .....	13		

## WARRANTY

# SAFETY SUMMARY

The warnings, cautions and instructions discussed in this instruction manual cannot cover all possible conditions or situations that could occur. It must be understood by the operator that common sense and caution are factors which cannot be built into this product, but must be supplied by the operator. Reading this operator's manual before using the welder will enable you to do a better, safer job. Learn the welder's applications and limitations as well as the specific potential hazards peculiar to welding.

## IMPORTANT SAFETY INFORMATION

The following safety information is provided as guidelines to help you operate your new welder under the safest possible conditions. Any equipment that uses electrical power can be potentially dangerous to use when safety or safe handling instructions are not known or not followed. The following safety information is provided to give the user the information necessary for safe use and operation.

A procedure step preceded by a **WARNING** is an indication that the next step contains a procedure that might be injurious to a person if proper safety precautions are not heeded.

A procedure preceded by a **CAUTION** is an indication that the next step contains a procedure that might damage the equipment being used.

A **NOTE** may be used before or after a procedure step to highlight or explain something in that step.

**READ ALL SAFETY INSTRUCTIONS CAREFULLY** before attempting to install, operate, or service this welder. Failure to comply with these instructions could result in personal injury and/or property damage.

**RETAIN THESE INSTRUCTIONS FOR FUTURE REFERENCE.**

### Note:

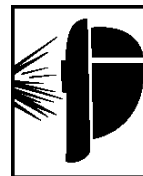
- The following safety alert symbols identify important safety messages in this manual.
- When you see one of the symbols shown here, be alert to the possibility of personal injury and carefully read the message that follows.



This symbol indicates that the possibility of electric shock hazard exists during the operation of the step(s) that follow.



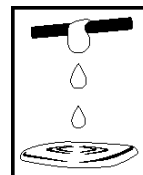
This symbol indicates that the possibility of fire hazard exists during the operation of the step(s) that follow.



This symbol indicates that the helmet must be worn during the step(s) that follow to protect against eye damage and burns due to flash hazard.



This symbol indicates that the possibility of toxic gas hazard exists during operation of the step(s) that follow.



This symbol indicates that the possibility of being burned by hot slag exists during operation of the step(s) that follow.



This symbol indicates that the eye protection should be worn to protect against flying debris in the following step(s).



This symbol indicates that the possibility of injury or death exists due to improper handling and maintenance of compressed gas cylinders or regulators.

- Published standards on safety are available. They are listed in **ADDITIONAL SAFETY INFORMATION** at the end of this **SAFETY SUMMARY**.

The National Electrical Code, Occupation Safety and Health Act regulations, local industrial codes and local inspection requirements also provide a basis for equipment installation, use, and service.

## SHOCK HAZARDS



### WARNING

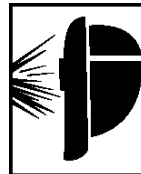
**ELECTRIC SHOCK CAN KILL!** To reduce the risk of death or serious injury from shock, read, understand, and follow the following safety instructions. In addition, make certain that anyone else who uses this welding equipment, or who is a bystander in the welding area understands and follows these safety instructions as well.

- **IMPORTANT! TO REDUCE THE RISK OF DEATH, INJURY, OR PROPERTY DAMAGE, DO NOT ATTEMPT OPERATION** of this welding equipment until you have read and understand the following safety summary.
- Do not, in any manner, come into physical contact with any part of the welding current circuit. The welding current circuit includes:
  - a. the work piece or any conductive material in contact with it,
  - b. the ground clamp,
  - c. the electrode or welding wire,
  - d. any metal parts on the electrode holder, or wire feed torch.
- Do not weld in a damp area or come in contact with a moist or wet surface.
- Do not attempt to weld if any part of clothing or body is wet.
- Do not allow the welding equipment to come in contact with water or moisture.
- Do not drag welding cables, wire feed torch, or welder power cord through or allow them to come into contact with water or moisture.
- Do not touch welder, attempt to turn welder on or off if any part of the body or clothing is moist or if you are in physical contact with water or moisture.
- Do not attempt to plug the welder into the power source if any part of body or clothing is moist, or if you are in physical contact with water or moisture.
- Do not connect welder work piece clamp to or weld on electrical conduit.
- Do not alter power cord or power cord plug in any way.
- Do not attempt to plug the welder

into the power source if the ground prong on power cord plug is bent over, broken off, or missing.

- Do not allow the welder to be connected to the power source or attempt to weld if the welder, welding cables, welding site, or welder power cord are exposed to any form of atmospheric precipitation, or salt water spray.
- Do not carry coiled welding cables around shoulders, or any other part of the body, when they are plugged into the welder.
- Do not modify any wiring, ground connections, switches, or fuses in this welding equipment.
- Wear welding gloves to help insulate hands from welding circuit.
- Keep all liquid containers far enough away from the welder and work area so that if spilled, the liquid can not possibly come in contact with any part of the welder or electrical welding circuit.
- Replace any cracked or damaged parts that are insulated or act as insulators such as welding cables, power cord, or electrode holder **IMMEDIATELY**.

## FLASH HAZARDS



### WARNING

**ARC RAYS CAN INJURE EYES AND BURN SKIN!** To reduce the risk of injury from arc rays, read, understand, and follow the following safety instructions. In addition, make certain that anyone else that uses this welding equipment, or is a bystander in the welding area understands and follows these safety instructions as well. Headshields and filter should conform to ANSI Z87.1 standards.

- Do not look at an electric arc without proper protection. A welding arc is extremely bright and intense and, with inadequate or no eye protection, the retina can be burned, leaving a permanent dark spot in the field of vision. A shield or helmet with a number 10 shade filter lens (minimum) must be used.
- Do not strike a welding arc until all bystanders and you (the welder) have welding shields and/or helmets in place.
- Do not wear a cracked or broken

helmet and replace any cracked or broken filter lenses IMMEDIATELY.

- Do not allow the uninsulated portion of the wire feed torch to touch the ground clamp or grounded work to prevent an arc flash from being created on contact.
- Provide bystanders with shields or helmets fitted with a #10 shade filter lens.
- Wear protective clothing. The intense light of the welding arc can burn the skin in much the same way as the sun, even through light-weight clothing. Wear dark clothing of heavy material. The shirt worn should be long sleeved and the collar kept buttoned to protect chest and neck.
- Protect against REFLECTED ARC RAYS. Arc rays can be reflected off shiny surfaces such as a glossy painted surface, aluminum, stainless steel, and glass. It is possible for your eyes to be injured by reflected arc rays even when wearing a protective helmet or shield. If welding with a reflective surface behind you, arc rays can bounce off the surface, then off the filter lens on the inside of your helmet or shield, then into your eyes. If a reflective background exists in your welding area, either remove it or cover it with something non-flammable and non-reflective. Reflective arc rays can also cause skin burn in addition to eye injury.

## FIRE HAZARDS



### WARNING

**FIRE OR EXPLOSION CAN CAUSE DEATH, INJURY, AND PROPERTY DAMAGE!** To reduce the risk of death, injury, or property damage from fire or explosion, read, understand, and follow the following safety instructions. In addition, make certain that anyone else that uses this welding equipment, or is a bystander in the welding area, understands and follows these safety instructions as well. REMEMBER! Arc welding, by nature, produces sparks, hot spatter, molten metal drops, hot slag, and hot metal parts that can start fires, burn skin, and damage eyes.

- Do not wear gloves or other clothing that contains oil, grease, or other flammable substances.

- Do not wear flammable hair preparations.
- Do not weld in an area until it is checked and cleared of combustible and/or flammable materials. BE AWARE that sparks and slag can fly 35 feet and can pass through small cracks and openings. If work and combustibles cannot be separated by a minimum of 35 feet, protect against ignition with suitable, snug-fitting, fire resistant, covers or shields.
- Do not weld on walls until checking for, and removing, combustibles touching the other side of the walls.
- Do not weld, cut, or perform other such work on used barrels, drums, tanks, or other containers that had contained a flammable or toxic substance. The techniques for removing flammable substance and vapors, to make a used container safe for welding or cutting, are quite complex and require special education and training.
- Do not strike an arc on a compressed gas or air cylinder or other pressure vessel. Doing so will create a brittle area that can result in a violent rupture immediately or at a later time as a result of rough handling.
- Do not weld or cut in an area where the air may contain flammable dust (such as grain dust), gas, or liquid vapors (such as gasoline).
- Do not handle hot metal, such as the work piece or electrode stubs, with bare hands.
- Wear leather gloves, heavy long sleeve shirt, cuffless trousers, high-topped shoes, helmet, and cap. As necessary, use additional protective clothing such as leather jacket or sleeves, fire resistant leggings, or apron. Hot sparks or metal can lodge in rolled up sleeves, trouser cuffs, or pockets. Sleeves and collars should be kept buttoned and pockets eliminated from the shirt front.
- Have fire extinguisher equipment handy for immediate use! A portable chemical fire extinguisher, type ABC, is recommended.
- Wear ear plugs when welding overhead to prevent spatter or slag from falling into ear.
- Make sure welding area has a good, solid, safe floor, preferably concrete or

masonry, not tiled, carpeted, or made of any other flammable material.

- Protect flammable walls, ceilings, and floors with heat resistant covers or shields.
- Check welding area to make sure it is free of sparks, glowing metal or slag, and flames before leaving the welding area.

## FUME HAZARDS



### WARNING

#### **FUMES, GASSES, AND VAPORS CAN CAUSE DISCOMFORT, ILLNESS, AND DEATH!**

To reduce the risk of discomfort, illness, or death, read, understand, and follow the following safety instructions. In addition, make certain that anyone else that uses this welding equipment or is a bystander in the welding area, understands and follows these safety instructions as well.

- Do not weld in an area until it is checked for adequate ventilation as described in ANSI standard #Z49.1. If ventilation is not adequate to exchange all fumes and gasses generated during the welding process with fresh air, do not weld unless you (the welder) and all bystanders are wearing air-supplied respirators.
- Do not heat metals coated with, or that contain, materials that produce toxic fumes (such as galvanized steel), unless the coating is removed. Make certain the area is well ventilated, and the operator and all bystanders are wearing air-supplied respirators.
- Do not weld, cut, or heat lead, zinc, cadmium, mercury, beryllium, or similar metals without seeking professional advice and inspection of the ventilation of the welding area. These metals produce **EXTREMELY TOXIC** fumes which can cause discomfort, illness, and death.
- Do not weld or cut in areas that are near chlorinated solvents. Vapors from chlorinated hydrocarbons, such as trichloroethylene and perchloroethylene, can be decomposed by the heat of an electric arc or its ultraviolet radiation. These actions can cause PHOSGENE, a HIGH-

LY TOXIC gas to form, along with other lung and eye-irritating gasses. Do not weld or cut where these solvent vapors can be drawn into the work area or where the ultraviolet radiation can penetrate to areas containing even very small amounts of these vapors.

- Do not weld in a confined area unless it is being ventilated or the operator (and anyone else in the area) is wearing an air-supplied respirator.
- Stop welding if you develop momentary eye, nose, or throat irritation as this indicates inadequate ventilation. Stop work and take necessary steps to improve ventilation in the welding area. Do not resume welding if physical discomfort persists.

## COMPRESSED GASSES AND EQUIPMENT HAZARDS



### WARNING

#### **IMPROPER HANDLING AND MAINTENANCE OF COMPRESSED GAS CYLINDERS AND REGULATORS CAN RESULT IN SERIOUS INJURY OR DEATH!**

To reduce the risk of injury or death from compressed gasses and equipment hazards, read, understand, and follow the following safety instructions. In addition, make certain that anyone else who uses this welding equipment or a bystander in the welding area understands and follows these safety instructions as well.

- Do not use flammable gasses with MIG welders. Only inert or nonflammable gasses are suitable for MIG welding. Examples are Carbon Dioxide, Argon, Helium, etc. or mixtures of more than one of these gasses.
- Do not attempt to mix gasses or refill a cylinder yourself. Do not expose cylinders to excessive heat, sparks, slag and flame, etc. Cylinders exposed to temperatures above 130°F will require water spray cooling.
- Do not expose cylinders to electricity of any kind.
- Do not use a cylinder or its contents for

anything other than its intended use. Do not use as a support or roller.

- Do not locate cylinders in passageways or work area where they may be struck.
- Do not use a wrench or hammer to open a cylinder valve that cannot be opened by hand. Notify your supplier.
- Do not modify or exchange gas cylinder fittings.
- Do not deface or alter name, number or other markings on a cylinder. Do not rely on cylinder color to identify the contents.
- Do not connect a regulator to a cylinder containing gas other than that for which the regulator was designed.
- Do not attempt to make regulator repairs. Send faulty regulators to manufacturer's designated repair center for repair.
- Do not attempt to lubricate a regulator.
- Always change cylinders carefully to prevent leaks and damage to their walls, valves, or safety devices.
- Always secure cylinders with a steel chain so that they cannot be knocked over.
- Always protect a cylinder, especially the valve, from bumps, falls, falling objects and weather. Remember that gasses in the cylinders are under pressure and damage to a regulator can cause the regulator or portion of the regulator to be explosively ejected from the cylinder.
- Always make certain the cylinder cap is securely in place on the cylinder, whenever the cylinder is moved.
- Always close the cylinder valve and immediately remove a faulty regulator from service, for repair, if any of the following conditions exist:
  - Gas leaks externally.
  - Delivery pressure continues to rise with down stream valve closed.
  - The gauge pointer does not move off the stop pin when pressurized or fails to return to the stop pin after pressure is released.

## **ADDITIONAL SAFETY INFORMATION**

For additional information concerning welding safety, refer to the following standards and comply with them as applicable.

- ANSI Standard Z49.1 – SAFETY IN WELDING AND CUTTING – obtainable from the American Welding Society, 550 NW Le Jeune Road, Miami, FL 33126 Telephone (800) 443-9353, Fax (305) 443-7559 – [www.amweld.org](http://www.amweld.org) or [www.aws.org](http://www.aws.org)
- ANSI Standard Z87.1 – SAFE PRACTICE FOR OCCUPATION AND EDUCATIONAL EYE AND FACE PROTECTION – obtainable from the American National Standards Institute, 11 West 42nd St., New York, NY 10036 Telephone (212) 642-4900, Fax (212) 398-0023 – [www.ansi.org](http://www.ansi.org)
- NFPA Standard 51B – CUTTING AND WELDING PROCESS – obtainable from the National Fire Protection Association, 1 Batterymarch Park, P.O. Box 9101, Quincy, MA 02269-9101 Telephone (617) 770-3000 Fax (617) 770-0700 – [www.nfpa.org](http://www.nfpa.org)
- OSHA Standard 29 CFR, Part 1910, Subpart Q., WELDING, CUTTING AND BRAZING – obtainable from your state OSHA office or U.S. Dept. of Labor OSHA, Office of Public Affairs, Room N3647, 200 Constitution Ave., Washington, DC 20210 – [www.osha.gov](http://www.osha.gov)
- CSA Standard W117.2 – Code for SAFETY IN WELDING AND CUTTING. – obtainable from Canadian Standards Association, 178 Rexdale Blvd., Etobicoke, Ontario M9W 1R3 – [www.csa.ca](http://www.csa.ca)
- American Welding Society Standard A6.0. WELDING AND CUTTING CONTAINERS WHICH HAVE HELD COMBUSTIBLES. – obtainable from the American Welding Society, 550 NW Le Jeune Road, Miami, FL 33126 Telephone (800) 443-9353, Fax (305) 443-7559 – [www.amweld.org](http://www.amweld.org) or [www.aws.org](http://www.aws.org)

# WELDER SPECIFICATIONS

## DESCRIPTION

Your new MIG (Metal Inert Gas) wire feed welder is designed for maintenance and sheet metal fabrication. The welder consists of a single-phase power transformer, stabilizer, rectifier, and a unique built-in control/feeder. Now you can weld sheet metal from 18 gauge up to 1/4 inch thick with a single pass. You can weld thicker steel with beveling and multiple pass techniques. Table 1 lists your MIG welder specifications.

**Table 1.** Welder Specifications

Primary (input) volts:	230 Vac
Primary (input) Amps:	25
Phase:	Single
Frequency:	60Hz
Secondary (output) volts:	21.3
Secondary (CSA output) amps:	145
Open Circuit Volts (Max.):	35 Vdc
Duty Cycle Rating:	15%

MIG welders equipped with gas are capable of welding with 0.023 (0.6mm) and 0.030 (0.8mm) solid steel wire on dc reverse polarity and with 0.030 (0.8mm) self-shielding flux-core wire on dc straight polarity. Larger, 0.035 inch (0.9mm) diameter solid steel wire, on dc reverse polarity may also be used on this welder. The use of larger diameter wire makes welding difficult and the results cannot be guaranteed. Use of larger than .035 diameter wire is not recommended.

## WELDER OPERATING CHARACTERISTICS

### DUTY CYCLE

The duty cycle rating of a welder defines how long the operator can weld and how long the welder must be rested and cooled. Duty cycle is expressed as a percentage of 10 minutes and represents the maximum welding time allowed. The balance of the 10-minute cycle is required for cooling.

Your new welder has a duty cycle rating of 15% at the rated output. This means that you can weld for one-and-a-half (1.5) minutes of 10 with the remaining eight-and-a-half (8.5) minutes required for cooling. (See Table 2).

**Table 2.** Duty Cycle Ratings

Duty Cycle Rating	Maximum Welding Time	Required Resting Time
15%	1.5 minutes	8.5 minutes
20%	2 minutes	8 minutes
25%	2.5 minutes	7.5 minutes
40%	4 minutes	6 minutes
60%	6 minutes	4 minutes
80%	8 minutes	2 minutes
100%	10 minutes	0 minutes

## INTERNAL THERMAL PROTECTION

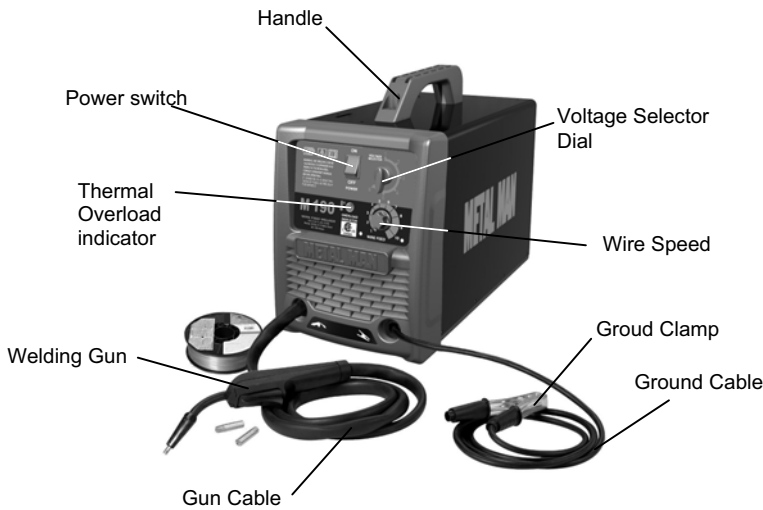
### CAUTION

Do not constantly exceed the duty cycle or damage to the welder can result. If you exceed the duty cycle of the welder, an internal thermal protector will open, shutting off all welder functions except the cooling fan. If this happens, DO NOT SHUT OFF THE WELDER. Leave the welder turned on with the fan running. After cooling, the thermal protector will automatically reset and the welder will function normally again. However you should wait at least ten minutes after the thermal protector opens before resuming welding. You must do this even if the thermal protector resets itself before the ten minutes is up or you may experience less than specified duty cycle performance.

If you find that the welder will not weld for one-and-a-half minutes without stopping, reduce the wire speed slightly and tune in the welder at the lowest wire speed setting that still produces a smooth arc. Welding with the wire speed set too high causes excessive current draw and shortens the duty cycle.



# KNOW YOUR WELDER



**Figure 1.** Model MIG190 Welder

**Handle** – Rugged, top mounted handle allows for easy transport of your welder.

**Wire Speed Control** – Use this dial to adjust the speed at which the welder feeds wire to the torch. 1 is the slowest wire feed speed, 10 is the highest. You will need to adjust or “tune-in” your wire speed for different welding conditions (thickness of metals, gas -vs- gasless welding, metal type, wire size, etc.). When the wire speed is properly “tuned-in” the welding wire will melt into the material you are welding as quickly as it is fed through the welding torch.

**Voltage Selectors** – The VOLTAGE selector controls the weld heat. There are six voltage (heat) selections available on this welder. Lower voltage (less heat) is achieved by setting the **Voltage Selector Dial** to A. Higher voltage (more heat) is achieved by setting the **Voltage Selector Dial** to F. Different materials and material thickness will require different voltage settings. You will need to adjust your voltage accordingly for different welding conditions. By properly adjusting your voltage settings and wire feed speed, you will enable clean, precision welds. (Refer to the Suggested Settings Chart on p.31 of this manual OR on the inside of the door of the welder.)

**Power Switch** – This switch turns the welder ON and OFF. (Make sure the power switch is

in the OFF position before performing any maintenance on the welder.)

**Power Cord** – This is a standard, NEMA 6-50P 50 amp 220 volt power cord. (Make sure you are using a properly grounded 220 Vac, 60Hz, single phase, 50 amp power source.)

**Ground Clamp** – Attaching the ground clamp to your work piece “completes” the welding current circuit. You must attach the ground clamp to the metal you are welding. If the ground clamp is not connected to the metal work piece you intend to weld, the welder will not have a completed circuit and you will be unable to weld. A poor connection at the ground clamp will waste power and heat. Scrape away dirt, rust, scale, oil or paint before attaching the ground clamp.

**Ground Cable** – The ground cable connects the ground clamp to the internal workings of the welder.

**Welding Torch and Cable** – The welding torch controls the delivery of the welding wire to the material to be welded. The welding wire is fed through the welding cable and welding torch when the welding torch trigger is pulled. You will need to install a contact tip and welding nozzle to the end of the welding torch, as described later in this manual, prior to welding.

**Circuit Breaker** – This unit is equipped with a circuit breaker switch which protects the welder’s power supply from line voltage surges. If circuit breaker is tripped, reset by pressing the button located inside the access panel on the dividing wall of the welder.

## Welding Terms

Now that you are familiar with the main parts of the welder, make note of the following terms. You will see them used throughout this manual.

**weld puddle:** The localized volume of molten metal in a weld prior to its solidification.

**weld angle:** The angle of the welding wire, as it extends from the welding torch, in relation to the item being welded.

**slag:** The protective coating that forms on the surface of molten metal.

**arc:** A sustained luminous discharge of electricity across a gap in a circuit.

**welding bead:** The extended build up of a weld, made by pushing or pulling the weld puddle.

# WELDER INSTALLATION

## POWER SOURCE CONNECTION

### POWER REQUIREMENTS

This welder is designed to operate on a properly grounded 220 volt, 60Hz, single-phase alternating current (ac) power source fused with a 50 amp time delayed fuse or circuit breaker. It is recommended that a qualified electrician verify the **ACTUAL VOLTAGE** at the receptacle into which the welder will be plugged and confirm that the receptacle is properly fused and grounded. The use of the proper circuit size can eliminate nuisance circuit breaker tripping when welding.

**DO NOT OPERATE THIS WELDER** if the **ACTUAL** power source voltage is less than 198 volts ac or greater than 240 volts ac. Contact a qualified electrician if this problem exists. Improper performance and/or damage to the welder will result if operated on inadequate or excessive power.

### CONNECT TO POWER SOURCE



## WARNING

### High voltage danger from power source!

Consult a qualified electrician for proper installation of receptacle at the power source. This welder must be grounded while in use to protect the operator from electrical shock. If you are not sure if your outlet is properly grounded, have it checked by a qualified electrician. Do not cut off the grounding prong or alter the plug in any way and do not use any adapters between the welder's power cord and the power source receptacle. Make sure the **POWER** switch is **OFF** then connect your welder's power cord to a properly grounded 220 Vac, 60 Hz, single phase, 50 amp power source.

### EXTENSION CORDS

For optimum welder performance, an extension cord should not be used unless absolutely necessary. If necessary, care must be taken in selecting an extension cord appropriate for use with your specific welder.

Select a properly grounded extension cord that will mate directly with the power source receptacle and the welder power cord without the use of adapters. Make certain that the extension cord is properly wired and in good electrical condition. Extension cords must be a #10 gauge cord at the smallest. Do not use an extension cord over 25 ft. in length.

### ASSEMBLING THE WELDER

The following procedures describe the process required to assemble, install, maintain, and prepare to weld with your new wire feed welder.

### UNPACKING THE WELDER

1. Remove any cartons or bags containing parts/accessories. (Most parts are shipped **INSIDE** the welder door.)
2. Open the cartons or bags packed with your welder and inspect their contents for damage.
3. Layout the parts and compare them to the the packing list in Table 3 to familiarize yourself with the parts and what they are called. This will help you when reading the manual.

### PACKING LIST

Table 3 contains a list of the items you will find packed in the carton.

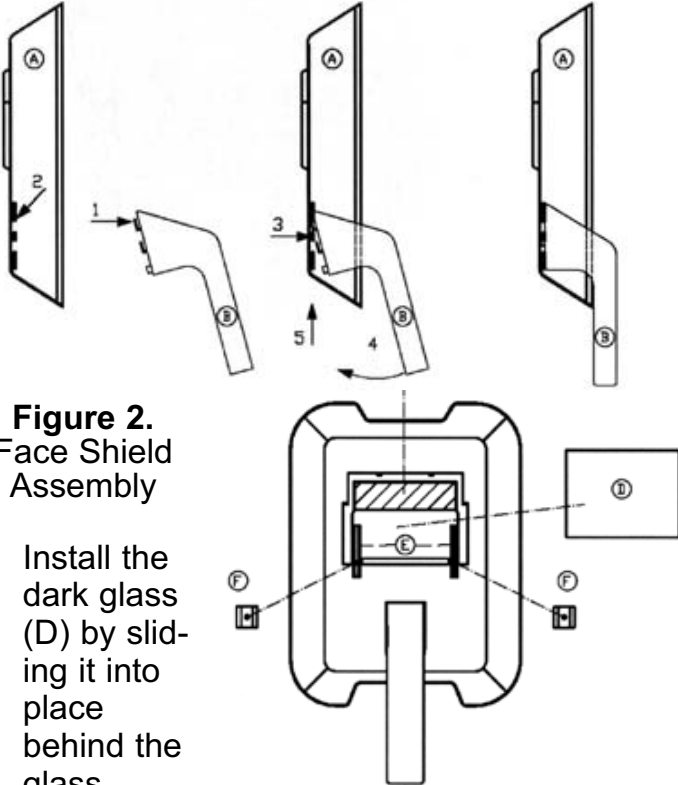
Table 3. Packing List

ITEM	QTY.
Welder	1
Face Shield	1
Face Shield Handle	1
Shaded Lens	1
Welder Handle	1
Handle Screws	2
Wire Brush/Hammer	1
Parts Bag	1
Contact Tips (.035, .030, .023)	1 each
Nozzle	1
Wire .030 Fluxcore	
Gas Hose	1
Hose Clamps	2
Manual, Instruction	1

### ASSEMBLE THE FACE SHIELD

1. Insert the upper tongue (1) of the handle (B) into the upper slot (2) on the face shield (A).

- Align the second tab on the handle with the second slot in the face shield by pushing the bottom of the handle in towards the face mask (4), while at the same time pushing upwards (5). (Alignment of the second tab is made easier by applying pressure to the point (3) shown below.)

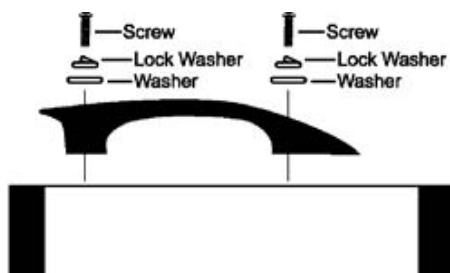


**Figure 2.**  
Face Shield  
Assembly

- Install the dark glass (D) by sliding it into place behind the glass retaining tabs (E).
- Once protective dark glass has been installed into face shield, secure it in place with the retaining clips (F). Align the holes on each of the retaining clips with the pins on the retaining tabs and firmly press into place.

### INSTALLING THE HANDLE

- Line up the holes in the handles with the holes on the top of the welder.
- Place a lock washer then a washer onto the welder handle screws.
- Insert the screws with the washers through the holes on the welder handle and into the top of the welder and tighten. (see Figure 3)



**Figure 3.** Handle Installation

### SELECTING SHIELDING GAS

The shielding gas plays an extremely important role in the MIG welding process. It is critical that the molten weld puddle be shielded from the atmosphere. The shielding gas creates a protective pocket around the weld puddle which keeps impurities in the air from infecting the weld. Inadequate shielding will result in porous, brittle welds.

Although there are many gasses and gas mixtures available for MIG welding, the following recommendations are based on the electrical output characteristics and metal thickness capabilities of this specific MIG welder.

#### Gas Selection For Steel Welding With Steel Wire

For either mild or low carbon (High Strength Structural) steel, use a gas mixture of 75% Argon and 25% Carbon Dioxide. **DO NOT USE** Argon gas concentrations higher than 75% on steel. The result will be extremely poor penetration, porosity, and brittleness of weld.

This gas mixture helps to prevent burn through and distortion on very thin steel yet provides good penetration on thicker steel. Its ability to minimize spatter results in clean, smooth weld appearances. In addition, it provides good puddle control when welding vertically or overhead.

#### Gas Selection For Stainless Steel Welding

The best shielding gas for stainless steel welding is a mixture of 90% Helium, 7.5% Argon, and 2.5% Carbon Dioxide. However, the 100% Argon, can also be used, but an increase in the area being heated by the arc will be experienced causing slightly greater distortion of the base metal.

#### Gas Selection For Steel Welding With Silicon Bronze Wire

Use only pure Argon when welding steel with Silicon-Bronze wire.

#### Gas Selection For Aluminum Welding with Aluminum Wire

Use only pure Argon when welding aluminum.

## INSTALL THE SHIELDING GAS



### WARNING

**IMPROPER HANDLING AND MAINTENANCE OF COMPRESSED GAS CYLINDERS AND REGULATORS CAN RESULT IN SERIOUS INJURY OR DEATH!** Always secure gas cylinders to the welding cart, a wall, or other fixed support to prevent the cylinder from falling over and rupturing. Read, understand, and follow all the COMPRESSED GASSES AND EQUIPMENT HAZARDS in the SAFETY SUMMARY at the front of this manual. Secure your gas cylinder to the welding cart, or other fixed support.

1. Remove the protective cap from the cylinder and inspect the regulator connecting threads for dust, dirt, oil, and grease. Remove any dust or dirt with a clean cloth. **DO NOT ATTACH YOUR REGULATOR IF OIL, GREASE, OR DAMAGE ARE PRESENT.**
2. Open the cylinder valve **FOR JUST AN INSTANT** to blow out any foreign matter inside the valve port. Never aim the open valve cylinder port at yourself or bystanders.
3. Screw the regulator into the cylinder valve and tighten with a wrench.
4. Firmly push the gas hose over barbed fittings on back of welder and regulator.
5. Secure both ends of hose onto barbed fittings with hose clamps.

## CHECK THE GAS FLOW



### WARNING

**IMPROPER HANDLING AND MAINTENANCE OF COMPRESSED GAS CYLINDERS AND REGULATORS CAN RESULT IN SERIOUS INJURY OR DEATH.**

To reduce the risk of injury or death, always stand to the side of the cylinder opposite the regulator when opening the cylinder valve, keeping the cylinder valve between you and the regulator. Never aim the open cylinder valve port at yourself or bystanders. Failure to comply with this warning could result in serious personal injury.

**Note:** If the cylinder you have is equipped with male regulator connecting threads instead of female, you will need to obtain a special compressed gas cylinder adapter from your gas supplier to install between your gas cylinder and regulator.

- The gas control function does not require the welder to be turned on or plugged in.
  - To avoid damage to your regulator, make sure you have the regulator valve closed before opening the cylinder valve (turn the regulator adjustment knob counterclockwise until the knob is fairly loose).
1. Slowly crack open the cylinder valve, then turn open **ALL THE WAY**.
  2. Pull the trigger on the torch to allow the gas to flow. **KEEP THE TRIGGER PULLED**. Listen and feel for gas flowing from the end of the welding torch. If your gas regulator has an adjustment knob to control the gas flow rate, turn the adjustment knob clockwise to increase gas flow; counterclockwise to reduce flow. For most welding, the gas flow should be set at 8-12 L.P.M. If no gas is heard or felt, verify all steps involved in connecting the gas.
  3. Release the trigger.

**Note:** If welding outside or in a draft, it may become necessary to set up a wind break to keep the shielding gas from being blown from the weld area.

**-MAKE SURE TO TURN OFF THE GAS CYLINDER VALVE WHEN DONE WELDING.**

## ALIGN AND SET THE DRIVE ROLLER

Before installing any welding wire into the unit, the proper sized groove must be placed into position on the wire drive mechanism.

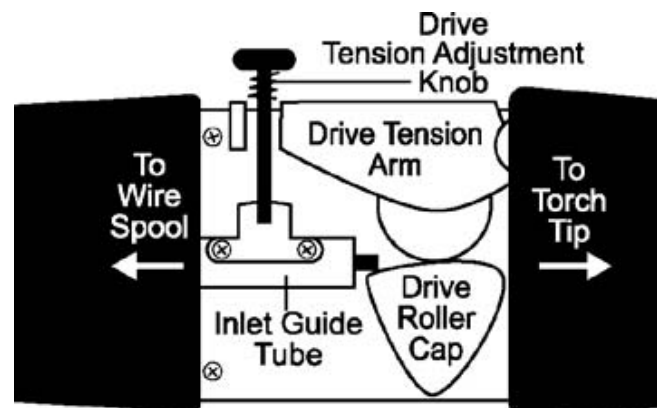
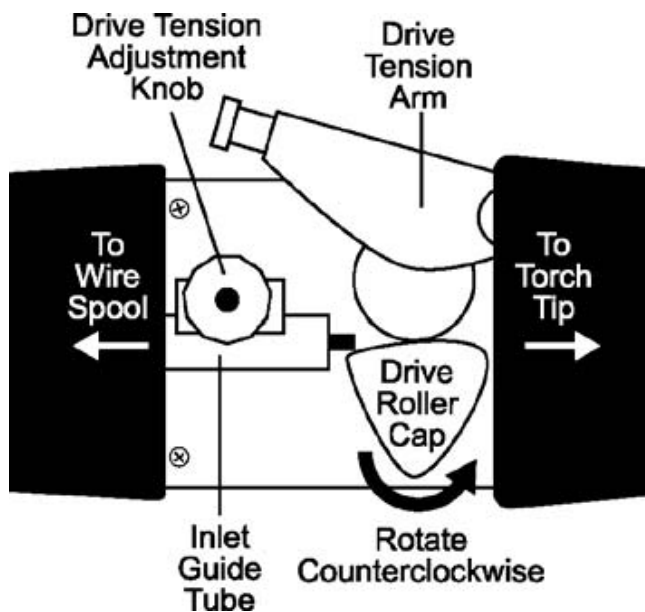


Figure 4. Feed Motor

Adjust the drive roller according to the following steps:

1. Open the door to the welder drive compartment.
2. Remove the drive tension by loosening the tension adjusting knob and lifting the Drive Tension Adjustor away from the Drive Tension Arm. Pull the drive tension arm away from the drive roller.
3. If there is wire already installed in the welder, roll it back onto the wire spool by hand-turning the spool counterclockwise. Be careful not to allow the wire to come out of the rear end of the inlet guide tube without holding onto it or it will unspool itself. Put the end of the wire into the hole on the outside edge of the wire spool and bend it over to hold the wire in place. Remove the spool of wire from the drive compartment of the welder.
4. Rotate the Drive Roller Cap counterclockwise and remove it from the Drive Roller.
5. Pull the Drive Roller off of the Drive Roller Shaft.



**Figure 5.** Drive Roller Adjustments

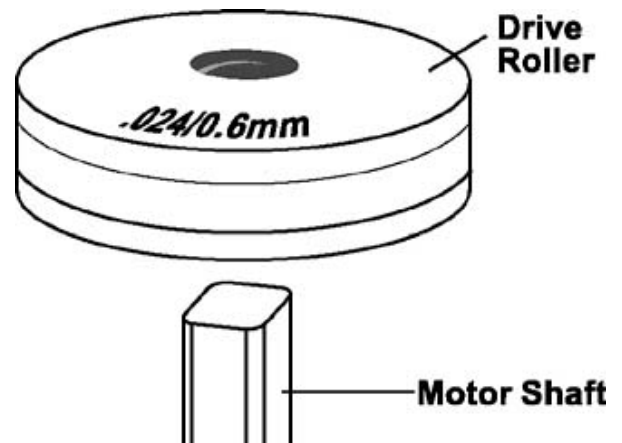
**Note:** The drive roller has two wire size grooves built into it. When installing the drive roller, the number stamped on the drive roller for the wire size you are using should be facing you. Use only the proper size drive roller when using your welder.

Table 4 indicates which drive roller groove should be used with each wire diameter size.

Wire Diameter	Drive Roller Groove:
.023 inch	0.6
.030 inch	0.9
.035 inch	0.9

**Table 4.** Drive Roller Sizing

4. Find the side of the drive roller that is stamped with the same wire diameter as that of the wire being installed (see Figure 6). Push the drive roller onto the drive roller shaft, with the side stamped with the desired wire diameter facing you.



**Figure 6.** Drive Roller

5. Reinstall the Drive Roller Cap and lock in place by turning it clockwise.
6. Close the door to the welder drive compartment.

### SELECTING THE WELDING WIRE

This welder uses both four inch and eight inch spools of 0.030 inch (0.8mm) or 0.035 inch (0.9mm) self shielding flux-core wire. Steel from 18 gauge up to 1/4 inch thick can be welded with this wire. It can also use up to 0.030 solid wire designed for MIG welding.

### NOTE:

- Metal thinner than 18 gauge cannot be welded with this machine. Attempting to do so will cause burn through (blowing holes) in the metal you are intending to weld.
- If a spool has developed heavy oxidation, the only solution to the problem is to discard the spool of wire.

If you have an oxidized spool of wire, do not discard it until you have unspooled a few turns of wire to see if the wire further down on the spool is in usable condition, if not, – discard the spool.

## INSTALL THE WELDING WIRE



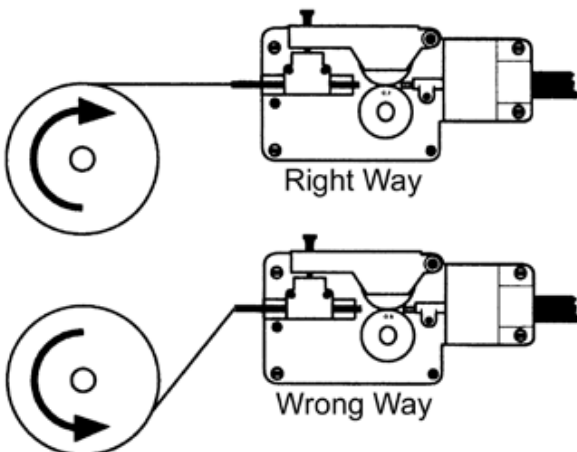
### WARNING

**Electric shock can kill!** Always turn the POWER switch OFF and unplug the power cord from the ac power source before installing wire.

**Tech Tip:** Before installing welding wire, make sure that you have removed any old wire from the Torch Assembly. This will help to prevent the possibility of the wire jamming inside the Torch Liner.

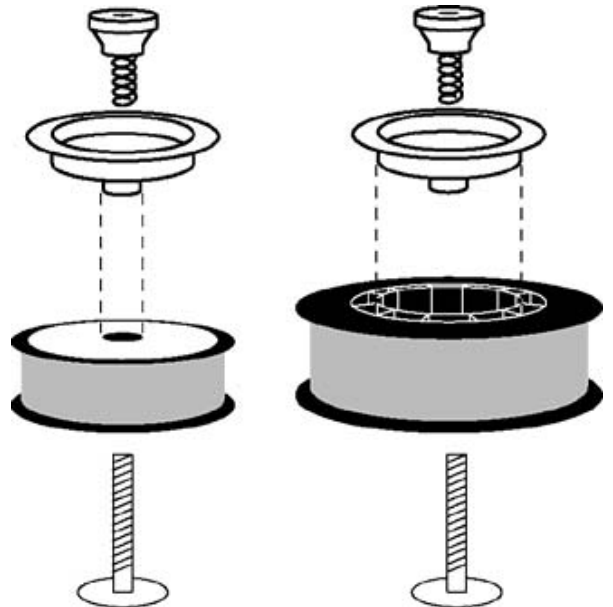
Be very careful when removing the welding nozzle. The contact tip on this welder is electrically hot whenever the torch trigger is pulled. Make certain POWER is turned OFF.

1. Remove the nozzle and contact tip from the end of the torch assembly.
2. Make sure the proper groove on the drive roller is in place for the wire being installed. If the proper groove is not in place, change the drive roller as described above.
3. Unwrap the spool of wire and then find the leading end of the wire (it goes through a hole in the outer edge of the spool and is bent over the spool edge to prevent the wire from unspooling), BUT DO NOT UNHOOK IT YET.
4. Place the spool on the spindle in such a manner that when the wire comes off the spool, it will look like the top illustration in Figure 7. The welding wire should always come off the top of the spool into the drive mechanism.



**Figure 7.** Wire Installation

5. If you are installing a four-inch spool of wire, install the drive brake hardware on the top of the spool of wire according to figure 8A. If you are installing an eight-inch spool, install the spindle adapter and drive brake hardware as shown in Figure 8B. The purpose of the drive brake is to cause the spool of wire to stop turning at nearly the same moment that wire feeding stops.
6. Once the drive brake hardware is installed, set the spool tension.
  - a) With one hand, turn the wire spool and continue turning it while adjusting the tension on the spool.
  - b) With your free hand, tighten (turn clockwise) the drive tension adjustment knob.
  - c) Stop tightening when drag is felt on the wire spool that you are turning, then stop hand-turning the wire spool.



**Figure 8A.** Drive Brake Hardware Installation

**Figure 8B.** Spindle Adapter and Drive Brake Installation

**Note:** If TOO MUCH tension is applied to the wire spool, the wire will slip on the drive roller or will not be able to feed at all. If TOO LITTLE tension is applied, the spool of wire will want to unspool itself. Readjust the drive brake tension as necessary to correct for either problem.

7. After checking to make sure that your welder is disconnected from the ac power source, free the leading end of the wire from the spool, but do not let go of it until told to do so, or the wire will unspool itself.
8. Using a wire cutter, cut the bent end off the leading end of the wire so that only a

- straight leading end remains.
9. Loosen the tension adjusting knob holding the drive tension arm in place and lift the tension arm up off the drive roller.
  10. Insert the leading end of the wire into the inlet guide tube. Then push it across the drive roller and into the torch assembly about six inches.

### CAUTION

Make certain that the welding wire is actually going into the torch liner. Be very sure it has not somehow been accidentally been routed alongside the liner or even in some other direction. If this should happen, the wire could feed inside the cable casing or take a right angle and follow the wires and gas hose inside the welder. It could also feed back on itself jamming up the mechanism.

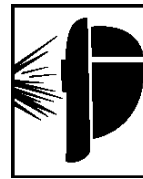
11. Line the wire up in groove of the drive roller, then allow the drive tension arm to drop onto the drive roller.
12. Flip the quick release drive tensioner back up into position on the drive tensioner arm.
13. Tighten (turn clockwise) the drive tension adjusting knob until the tension roller is applying enough force on the wire to prevent it from slipping out of the drive assembly.
14. Let go of the wire.
15. Connect the welder power cord to the ac power source. Turn the welder ON. Set the VOLTAGE switch to the voltage (heat) setting recommended for the gauge metal that is to be welded. Refer to the label mounted on the cover, inside the drive compartment, for recommended voltage (heat) settings for your welding job. The VOLTAGE selector controls the weld heat. There are four voltage heat selections (lettered A through D) available on this welder. Position A provides the lowest voltage (heat) and position D the highest voltage (heat).
16. Set the WIRE SPEED control to the middle of the wire speed range.
17. Straighten the torch cable and pull the trigger on the welding torch to feed the wire through the torch assembly.
18. When at least an inch of wire sticks out past the end of the torch, release the trigger.

19. Turn the Power Switch to the OFF position.
20. Select a contact tip stamped with the same diameter as the wire being used. If stamped in metric see Table 4 on p. 13 of this manual.

**Note:** Due to inherent variances in flux-cored welding wire, it may be necessary to use a contact tip one size larger than your flux core wire if wire jams occur.

21. Slide the contact tip over the wire (protruding from the end of the torch). Thread the contact tip into the end of the torch and hand-tighten securely.
22. Install the nozzle on the torch assembly. For best results, coat the inside of the nozzle with anti-stick spray or gel.
23. Cut off the excess wire that extends past the end of the nozzle.
24. Turn the welder ON.

### SET THE WIRE DRIVE TENSION



### WARNING

To reduce the risk of arc flash, make certain that the wire coming out of the end of the torch does not come in contact with work piece, ground clamp or any grounded material during the drive tension setting process or arcing will occur.

1. Pull the trigger on the torch.
2. Turn the drive tension adjustment knob clockwise, increasing the drive tension until the wire seems to feed smoothly without slipping.

When set correctly, there should be no slippage between the wire and the drive roller under normal conditions. If an obstruction occurs along the wire feed path, the wire should then slip on the drive roller.

After the tension is properly adjusted, the quick release drive tensioner may be unlocked and relocked and no readjustment of the drive tension adjustment knob will be necessary (unless the diameter or type of wire is changed).

## CHANGE POLARITY

This welder allows you the capability to change the welding current polarity. You may select either dc Straight (dc - Flux Cored) or dc Reverse Polarity (dc + MIG). For welding steel with solid wire, stainless steel, flux cored hardfacing of steel, and silicon bronze welding of steel, select dc Reverse Polarity (dc + MIG). When using self-shielding, flux-core steel wire, use dc Straight Polarity (dc - Flux Cored).

Change the polarity of your welder according to the following procedure steps. Figure 9 shows what the polarity block should look like for each polarity setting.



### WARNING

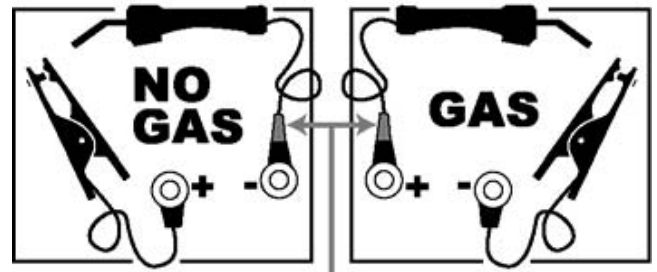
**Electric shock can kill!** Always turn the power OFF and unplug the power cord from the ac power source before changing polarity.

### CAUTION

Do not use a ratchet, crescent or other lever type wrench to tighten knobs on the polarity block. The nuts must be hand tightened only. Too much torque applied to one of the knobs could cause the knob to break off.

1. Remove the retaining knobs from the + and - mounting posts on the Gas/No Gas Board, located just below the drive motor on the inside of your welder.
  - A. For Gasless welding, mount the Ground Clamp ring terminal to the "+" mounting post and the Torch ring terminal to the "-" mounting post.
  - B. For Gas (MIG) welding, mount the Ground Clamp ring terminal to the "-" mounting post and the Torch ring terminal to the "+" mounting post.

See configuration shown in Figure 9.



NOTE: Torch cable is marked with RED.

Figure 9. Changing Polarity

2. Attach the ground clamp to the work piece, making sure that it is cleaned of dirt, oil, rust, scale, oxidation, and paint at the point of connection.

**Note:** It is best to connect the ground clamp directly to the work piece and as close to the weld as possible. If it is impractical to connect the ground clamp directly to the work piece, connect it to metal that is securely attached to the work piece, but not electrically insulated from it. Make certain this other metal is of equal or greater thickness than that of the workpiece.



### CAUTION

**Risk of electric component damage!** If the ground clamp is being connected to an automobile or other equipment with on-board computer systems, solid state electronic controls, solid state sound systems, etc., do not weld until disconnecting the battery that is attached to the chassis ground. Failure to do so may result in electronic component damage.



## OPERATION

Operation of this welder consists of selecting and adjusting operating controls for optimum voltage (welding heat) and wire speed settings.

### CONTROLS AND INDICATORS



#### WARNING

**Electric shock can kill!** Whenever the Torch Trigger switch is in the ON position, the welding circuit is activated. Under this condition, an arc will occur if the welding wire or any part of the welding circuit comes in contact with welding ground.

**POWER SWITCH** - The power switch supplies electrical current to the welder. Whenever the power switch is in the ON position, the welding circuit is activated. ALWAYS turn the power switch to the OFF position and unplug the welder before performing any maintenance.

**VOLTAGE SELECTORS** - The voltage selector dial controls the welding heat. The voltage selector dial is lettered A-F. Letter A is the lowest heat and letter F is the highest. Refer to the label inside the welder side door (or on page 31 of this manual) for recommended voltage selector settings for your welding job. Position F on the Voltage Selector produces the rated output of 145 amps.

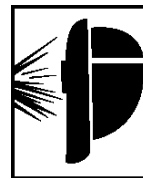
**WIRE SPEED CONTROL** - The wire speed control adjusts the speed at which the wire is fed out of the welding torch. The wire speed needs to be closely matched (tuned-in) to the rate at which it is being melted off. Some things that affect wire speed selection are the type and diameter of the wire being used, the heat setting selected, and the welding position to be used.

**Note:** The wire will feed faster without an arc. When an arc is being drawn, the wire speed will slow down.

### TUNING IN THE WIRE SPEED

This is one of the most important parts of MIG welder operation and must be done before starting each welding job or whenever any of the following variables are changed: heat setting, wire diameter, or wire type.

1. Connect the Ground Clamp to a scrap piece of the same type of material which you will be welding. It should be equal to or greater than the thickness of the actual work piece, and free of oil, paint, rust, etc.
2. Select a heat setting.
3. Hold the torch in one hand, allowing the nozzle to rest on the edge of the work-piece farthest away from you, and at an angle similar to that which will be used when welding. (See HOLDING THE TORCH on page 18 if you are uncertain of the angle at which you will be welding)
4. With your free hand, turn the Wire Speed Dial to maximum and continue to hold onto the knob.



#### WARNING

**EXPOSURE TO A WELDING ARC IS EXTREMELY HARMFUL TO THE EYES AND SKIN!** Prolonged exposure to the welding arc can cause blindness and burns. Never strike an arc or begin welding until you are adequately protected. Wear flameproof welding gloves, a heavy long sleeved shirt, cuffless trousers, high topped shoes, and a welding helmet.

5. Lower your welding helmet and pull the trigger on the torch to start an arc, then begin to drag the torch toward you while simultaneously turning the Wire Speed Dial counter-clockwise.
6. LISTEN! As you decrease the wire speed, the sound that the arc makes will change from a sputtering to a high-pitched buzzing sound and then will begin sputtering again if you decrease the wire speed too much. The point on the wire speed adjustment where the high-pitched buzzing sound is achieved is the correct setting.

You can use the wire speed control to slightly increase or decrease the heat and penetration for a given heat setting by selecting higher or lower wire speed settings. Repeat this tune-in procedure if you select a new heat setting, a different diameter wire, or a different type of welding wire.

## LEARNING TO WELD

MIG (Metal Inert Gas) welding is the process of uniting metallic parts by heating and allowing the metals to flow together through the use of an electrical arc. The electrical arc is created between a continuous consumable wire electrode (the welding wire) and the work piece. An inert shielding gas is used to protect the weld puddle from contamination and enhance the welding capabilities of the electrical arc.

Whether you have welded before or not, it is important that you become familiar with your new welder, its controls, and the results achieved at different settings. We strongly recommend that you practice with your new welder on scrap metal trying different heat settings, base metal thicknesses, and welding positions for each type and size of wire you will be using. By doing this you will gain a feel for how changes in these welding variables affect the weld.

Of course, if you have not welded before, you will need to develop welding skills and techniques as well.

The self-taught welder learns through a process of trial and error. The best way to teach yourself how to weld is with short periods of practice at regular intervals. All practice welds should be done on scrap metal that can be discarded. Do not attempt to make any repairs on valuable equipment until you have satisfied yourself that your practice welds are of good appearance and free of slag or gas inclusions. What you fail to learn through practice will be learned through mistakes and re-welds later on.

## HOLDING THE TORCH

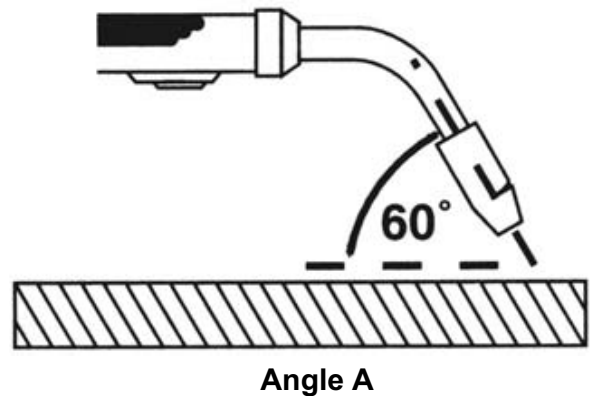
The best way to hold the welding torch is the way that feels most comfortable to you. While practicing to use your new welder, experiment holding the torch in different posi-

tions until you find the one that seems to work best for you. Refer to WELDING POSITIONS - p.20)

### Position the Torch to the Work Piece

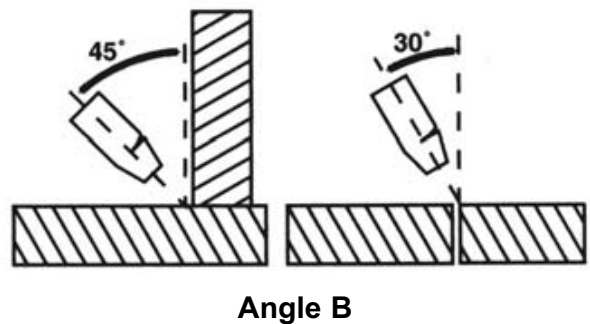
There are two angles of the torch nozzle in relation to the work piece that must be considered when welding.

1. Angle A (Figure 10) can be varied, but in most cases the optimum angle will be 60 degrees, the point at which the torch handle is parallel to the work piece. If angle A is increased, penetration will increase. If angle A is decreased, penetration will decrease also.



**Figure 10.** Torch Position, Angle A

2. Angle B (Figure 11) can be varied for two reasons: to improve the ability to see the arc in relation to the weld puddle and to direct the force of the arc.



**Figure 11.** Torch Position, Angle B

The force of the welding arc follows a straight line out of the end of the nozzle. If angle B is changed, so will the direction of arc force and the point at which penetration will be concentrated.

On a butt weld joint, the only reason to vary angle B from perpendicular (straight up) to the work piece would be to improve visibility of the weld puddle. In this case, angle B can be varied anywhere from zero to 45 degrees

with 30 degrees working about the best. On a fillet weld joint, the nozzle is generally positioned in such a manner so as to split the angle between the horizontal and vertical members of the weld joint. In most cases, a fillet weld will be 45 degrees.

### Distance from the Work Piece

The end of the welding torch is designed with the contact tip recessed from the end of the nozzle and the nozzle electrically insulated from the rest of the torch. This permits the operator to actually rest the nozzle on the work piece and drag it along while welding. This can be very helpful to beginning welders to steady the torch, allowing the welder to concentrate on welding technique. If the nozzle is held off the work piece, the distance between the nozzle and the work piece should be kept constant and should not exceed 1/4 inch or the arc may begin sputtering, signaling a loss in welding performance.

## WELDING TECHNIQUES



### WARNING

**EXPOSURE TO A WELDING ARC IS EXTREMELY HARMFUL TO THE EYES AND SKIN!** Prolonged exposure to the welding arc can cause blindness and burns. Never strike an arc or begin welding until you are adequately protected. Wear flameproof welding gloves, a heavy long sleeved shirt, cuffless trousers, high topped shoes and a welding helmet.



### WARNING

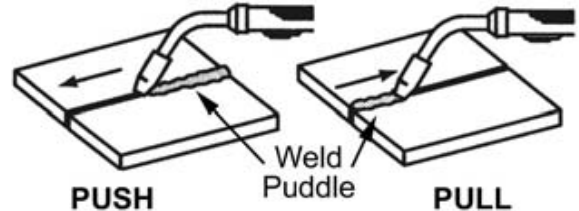
**ELECTRIC SHOCK CAN KILL!** To prevent ELECTRIC SHOCK, do not perform any welding while standing, kneeling, or lying directly on the grounded work.

### MOVING THE TORCH

Torch travel refers to the movement of the torch along the weld joint and is broken into two elements: Direction and Speed. A solid weld bead requires that the welding torch be

moved steadily and at the right speed along the weld joint. Moving the torch too fast, too slow, or erratically will prevent proper fusion or create a lumpy, uneven bead.

1. **TRAVEL DIRECTION** is the direction the torch is moved along the weld joint in relation to the weld puddle. The torch is either **PUSHED** (see Figure 12) into the weld puddle or **PULLED** away from the weld puddle.



**Figure 12.** Travel Direction

For most welding jobs you will pull the torch along the weld joint to take advantage of the greater weld puddle visibility.

2. **TRAVEL SPEED** is the rate at which the torch is being pushed or pulled along the weld joint. For a fixed heat setting, the faster the travel speed, the lower the penetration and the lower and narrower the finished weld bead. Likewise, the slower the travel speed, the deeper the penetration and the higher and wider the finished weld bead.

### TYPES OF WELD BEADS

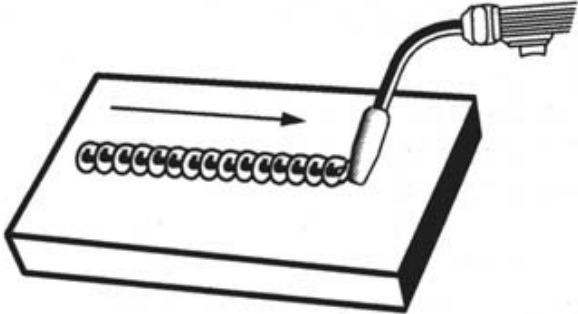
The following paragraphs discuss the most commonly used welding beads.

Once you have the torch in position with the wire lined up on the weld joint, lower your helmet, pull the trigger and the arc will start. In a second or two you will notice a weld puddle form and the base of the bead beginning to build. It is now time to begin to move with the torch. If you are just learning to weld, simply move the torch in a straight line and at a steady speed along the weld joint. Try to achieve a weld with the desired penetration and a bead that is fairly flat and consistent in width.

As you become more familiar with your new welder and better at laying some simple weld beads, you can begin to try some different weld bead types.

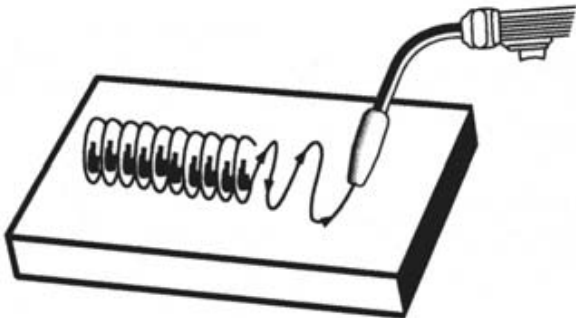
There are two basic types of weld beads, the stringer bead and the weave bead.

1. The **STRINGER BEAD** (Figure 13) is formed by traveling with the torch in a straight line while keeping the wire and nozzle centered over the weld joint. This is the easiest type of bead to make.



**Figure 13.** Stringer Bead

2. The **WEAVE BEAD** (Figure 14) is used when you want to deposit metal over a wider space than would be possible with a stringer bead. It is made by weaving from side to side while moving with the torch. It is best to hesitate momentarily at each side before weaving back the other way.

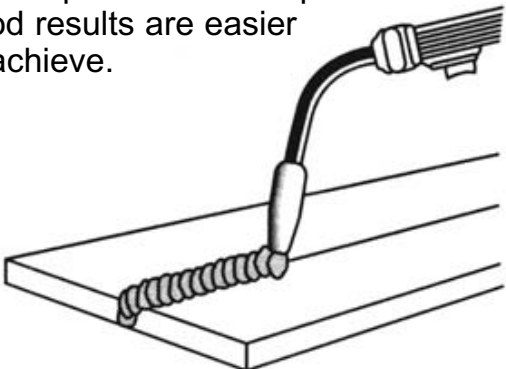


**Figure 14.** Weave Bead

### **WELDING POSITIONS**

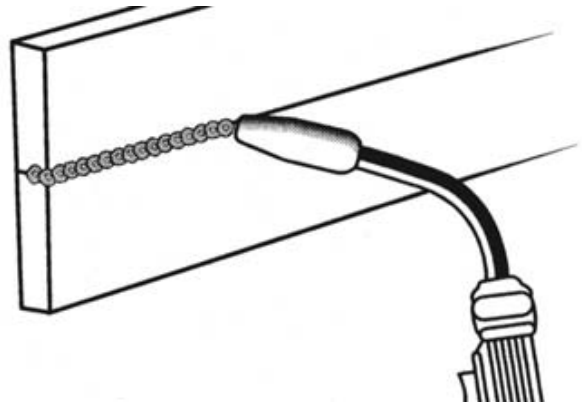
There are four basic welding positions: flat, horizontal, vertical, and overhead.

1. The **FLAT POSITION** (Figure 15) is the easiest of the welding positions and is most commonly used. It is best if you can weld in the flat position if at all possible as good results are easier to achieve.



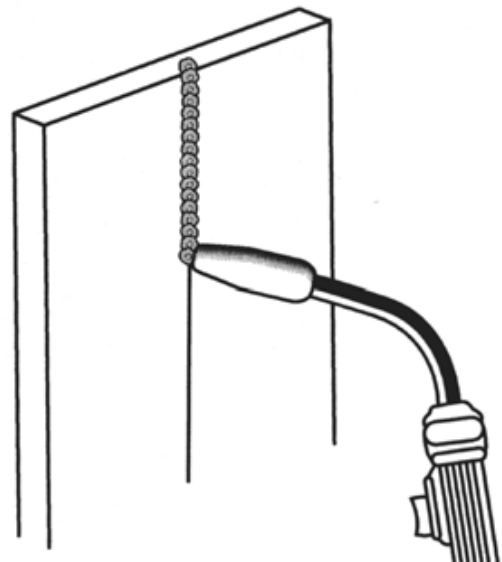
**Figure 15.** Flat Position

2. The **HORIZONTAL POSITION** (Figure 16) is next in difficulty level. It is performed very much the same as the flat weld except that angle B (see **HOLDING THE TORCH** - p.18) is such that the wire, and therefore the arc force, is directed more toward the metal above the weld joint. This is to help prevent the weld puddle from running downward while still allowing slow enough travel speed to achieve good penetration. A good starting point for angle B is about 30 degrees **DOWN** from being perpendicular to the work piece.

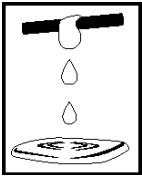


**Figure 16.** Horizontal Position

3. The **VERTICAL POSITION** (Figure 17) is the next most difficult position. Pulling the torch from top to bottom may be easier for many people, but in some instances it can be difficult to prevent the puddle from running downward. Pushing the torch from bottom to top may provide better puddle control and allow slower rates of travel speed to achieve deeper penetration. When vertical welding, angle B (see **HOLDING THE TORCH** - p.18) is usually always kept at zero, but angle A will generally range from 45 to 60 degrees to provide better puddle control.



**Figure 17.** Vertical Position



## WARNING

Hot slag can cause fires and serious injury from burns! Be sure to wear protective clothing, eye, and ear gear when using the Overhead Position.

4. The OVERHEAD POSITION (Figure 18) is the most difficult welding position because gravity is pulling at the weld puddle trying to make it drip off the work piece. Angle A (see HOLDING THE TORCH - p.18) should be maintained at 60 degrees, the same as in the flat position. Maintaining this angle will reduce the chances of molten metal falling into the nozzle should it drip from the weld puddle. Angle B should be held at zero degrees so that the wire is aiming directly into the weld joint. If you experience excessive dripping of the weld puddle, select a lower heat setting. Also, the weave bead tends to work better than the stringer bead when welding overhead.

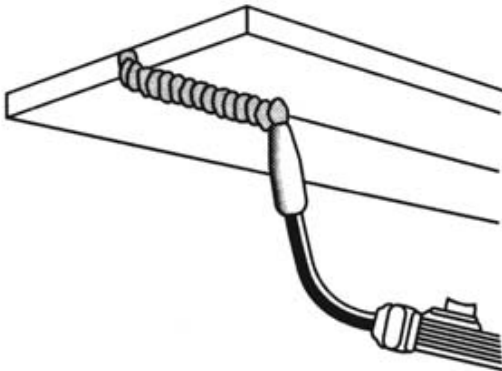


Figure 18. Overhead Position

## MULTIPLE PASS WELDING

**Butt Weld Joints.** When butt welding thicker materials, you will need to prepare the edges of the material to be joined by grinding a bevel on the edge of one or both pieces of the metal being joined. When this is done, a V is created between the two pieces of metal, that will have to be welded closed. In most cases more than one pass or bead will need to be laid into the joint to close the V. Laying more than one bead into the same weld joint is known as a multiple-pass weld.

The illustrations in Figure 19 show the sequence for laying multiple pass beads into a single V butt joint.

**NOTE:** WHEN USING SELF-SHIELDING FLUX-CORE WIRE it is very important to thoroughly chip and brush the slag off each completed weld bead before making another pass or the next pass will be of poor quality.

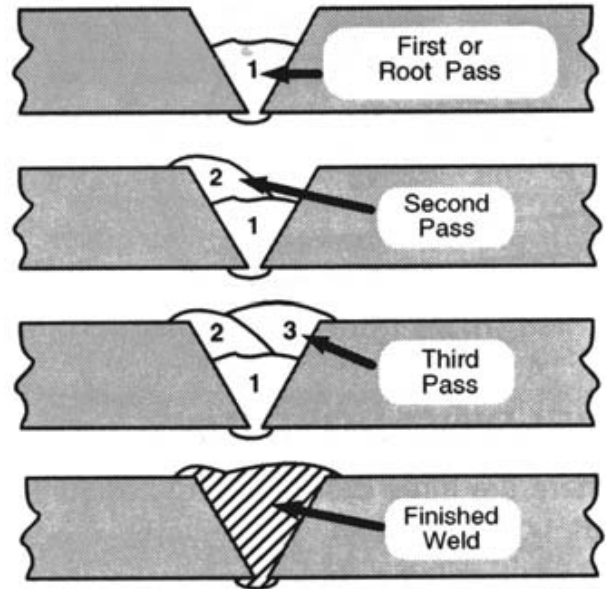


Figure 19. Butt Joints

**Fillet Weld Joints.** Most fillet weld joints, on metals of moderate to heavy thickness, will require multiple pass welds to produce a strong joint. The illustrations in Figure 20 show the sequence of laying multiple pass beads into a T fillet joint and a lap fillet joint.

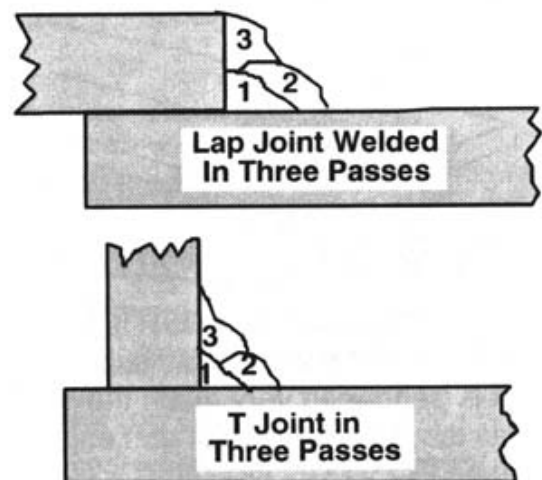


Figure 20. Fillet Weld Joints

## SPECIAL WELDING METHODS

### SPOT WELDING

The purpose of a spot weld is to join pieces of metal together with a spot of weld instead of a continuous weld bead. There are three methods of spot welding: Burn-Through, Punch and Fill, and Lap (see Figure 21). Each has advantages and disadvantages depending on the specific application as well as personal preference.

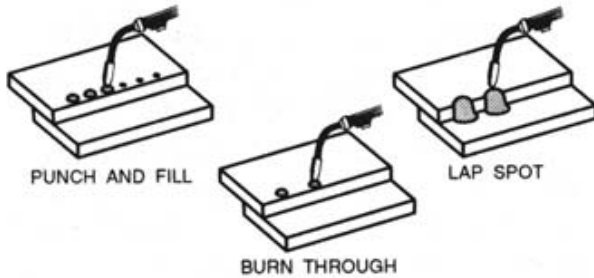


Figure 21. Spot Welding

1. The BURN-THROUGH METHOD welds two overlapped pieces of metal together by burning through the top piece and into the bottom piece.

With the burn-through method, larger wire diameters tend to work better than smaller diameters because they have greater current carrying capabilities allowing the arc to burn through very quickly while leaving a minimal amount of filler metal build up. Wire diameters that tend to work best, with the burn-through method, are 0.030 inch diameter solid wire or 0.035 inch self-shielding flux-core wire.

Do not use 0.023 inch diameter solid or 0.030 inch self-shielding flux-core wires when using the burn-through method unless the metal is VERY thin or excessive filler metal build-up and minimal penetration is acceptable.

Always select the HIGH heat setting with the burn-through method and tune in the wire speed prior to making a spot weld.

2. The PUNCH AND FILL METHOD produces a weld with the most finished appearance of the three spot weld methods. In this method, a hole is punched or drilled into the top piece of metal and the

arc is directed through the hole to penetrate into the bottom piece. The puddle is allowed to fill up the hole leaving a spot weld that is smooth and flush with the surface of the top piece.

Select the wire diameter, heat setting, and tune in the wire speed as if you were welding the same thickness material with a continuous bead.

3. The LAP SPOT METHOD directs the welding arc to penetrate the bottom and top pieces, at the same time, right along each side of the lap joint seam.

Select the wire diameter, heat setting, and tune in the wire speed as if you were welding the same thickness material with a continuous bead.

### SPOT WELDING INSTRUCTIONS

1. Select the wire diameter and heat setting recommended above for the method of spot welding you intend to use.
2. Tune in the wire speed as if you were going to make a continuous weld.
3. Hold the nozzle piece completely perpendicular to and about 1/4 inch off the work piece.
4. Pull the trigger on the torch and release it when it appears that the desired penetration has been achieved.
5. Make practice spot welds on scrap metal, varying the length of time you hold the trigger, until a desired spot weld is made.
6. Make spot welds on the actual work piece at desired locations.

# MAINTENANCE

## GENERAL

This welder has been engineered to give many years of trouble-free service providing that a few very simple steps are taken to properly maintain it.

1. Keep the wire drive compartment lid closed at all times unless the wire needs to be changed or the drive tension needs adjusting.
2. Keep all consumables (contact tips, nozzles, and torch liner) clean and replace when necessary. See CONSUMABLE MAINTENANCE and TROUBLESHOOTING later in this section for detailed information.
3. Replace power cord, ground cable, ground clamp, or torch assembly when damaged or worn.
4. Periodically clean dust, dirt, grease, etc. from your welder. Every six months, or as necessary, remove the side panels from the welder and air-blow any dust and dirt that may have accumulated inside the welder.



## WARNING

**Electric shock can kill!** To reduce the risk of electric shock, always unplug the welder from its ac power source before removing side panels.

## CONSUMABLE MAINTENANCE

IT IS VERY IMPORTANT TO MAINTAIN THE CONSUMABLES TO AVOID THE NEED FOR PREMATURE REPLACEMENT OF THE TORCH ASSEMBLY.

The **TORCH LINER** is intended to provide an unrestricted path for the welding wire to flow through the torch assembly. Over time the liner will accumulate dust, dirt, and other debris. Replacement is necessary when these accumulations begin to restrict the free flow of wire through the torch assembly.

## MAINTAINING THE CONTACT TIP

The purpose of the CONTACT TIP is to transfer welding current to the welding wire while allowing the wire to pass through it smoothly.

Always use a contact tip stamped with the same diameter as the wire it will be used with.

**Note:** Due to inherent variances in flux-cored welding wire, it may be necessary to use a contact tip one size larger than your flux core wire if wire jams occur.

1. If the wire burns back into the tip, remove the tip from the torch and clean the hole running through it with an oxygen-acetylene torch tip cleaner or tip drill.
2. Over time, the hole in the contact tip will become worn by the wire passing through it. The more worn this hole becomes, the less efficient is the transfer of welding current to the wire and eventually arc breakage and difficult arc starting will result. Replace contact tips when signs of wear become apparent.

## MAINTAINING THE NOZZLE

The nozzle directs the shielding gas to the weld puddle, determines the size of the shielding area, and prevents the electrically hot contact tip from contacting the work piece.

## CAUTION

**KEEP THE NOZZLE CLEAN!** During the welding process, spatter and slag will build up inside the nozzle and must be cleaned out periodically. Failure to clean and/or replace the nozzle in a timely fashion WILL CAUSE DAMAGE TO THE FRONT-END OF THE TORCH ASSEMBLY.

For best results, coat the inside of a new, or freshly cleaned nozzle with anti stick spray or gel.

1. Stop welding and clean any accumulated slag or spatter from the nozzle every 5 to 10 minutes of welding time.
2. When welding overhead, if any molten metal drips from the weld puddle and falls into the nozzle, STOP WELDING IMMEDIATELY and clean the nozzle.
3. If the slag cannot be thoroughly cleaned from the nozzle, REPLACE THE NOZZLE!

Failure to keep the nozzle adequately cleaned can result in the following problems:

A **SHORTED** nozzle results when spatter buildup bridges the insulation in the nozzle, allowing welding current to flow through it as well as the contact tip. When shorted, a nozzle will steal welding current from the wire whenever it contacts the grounded work piece. This causes erratic welds and reduced penetration. In addition, a shorted nozzle overheats the end of the torch, which can **DAMAGE** the front-end of the torch.

A **RESTRICTED** nozzle is created when enough slag builds up in the nozzle to affect the direction, concentration, and/or rate of the shielding gas flow. This problem can cause porous, brittle welds and reduce penetration.

### **TESTING FOR A SHORTED NOZZLE**

Arcing between the nozzle and the work piece **ALWAYS** means the nozzle is shorted, but this can be hard to detect through the lens of a welding helmet. The following testing method is another way to tell if a nozzle is shorted.

With the welder unplugged from the ac power source, touch the probes of an ohmmeter or continuity tester to the end of the contact tip and the outside of the nozzle. If there is any continuity at all, the nozzle **IS** shorted. Clean or replace as needed.

### **REPLACE A TORCH LINER**

When installing a new torch liner, care must be taken not to kink or otherwise damage the torch liner. See Figure 22 for the drive assembly and Figure 23 for the torch assembly.

1. Turn OFF welder **POWER SWITCH** and unplug welder from power supply.
2. Open the welder side panel.
3. Loosen the tension arm and lift it up off the drive roller.
4. Turn the wire spool counter-clockwise (be sure to hold onto the wire itself while turning the spool or the wire will unspool itself when it becomes free of the torch liner), and remove wire from the welder.
5. Lay torch cable and torch handle straight out in front of unit.
6. Remove torch Strain Relief Clamp by removing the four screws.

7. Take torch handle halves apart by removing four phillips head screws.
8. Remove the hanging hook from the two case halves by carefully pulling it apart until it is free from the torch.
9. Remove liner from gas block by pulling it from the bottom of the gas block, being careful not to separate gas block halves.
10. Remove liner from outer torch sleeve by pulling from torch end.
11. Install new liner, starting from torch end and feeding towards unit.
12. Push the new liner back through gas block and into the neck of the torch until it is fully seated then push into the groove at the rear or base of the block.
13. Return all components to the handle casing and realign them as they were originally.

Tech Tip: Be sure all o-ring's have been returned to their original positions.

14. Fit liner for length at feeder end by cutting liner with wire cutters.
15. Reinstall liner holding clamp at feeder.
16. With both halves of the handle case in place, tighten the four phillips head screws.
17. Replace hanging hook.
18. Reinstall the welding wire according to specifications in **INSTALL THE WELDING WIRE** section.
19. Close side panel.
20. Plug welder into power supply and turn **POWER SWITCH** to ON position.



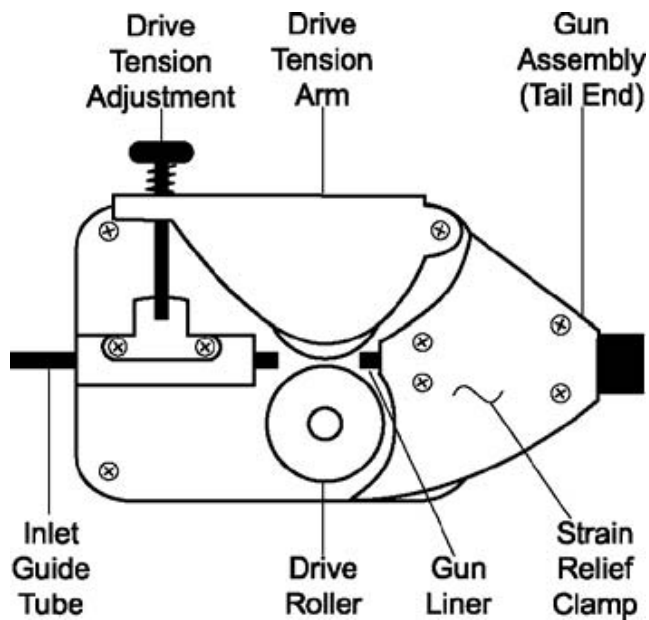


Figure 22. Drive Assembly

## PREVENTIVE MAINTENANCE

Except for internal and external cleaning, cleaning the nozzle, and occasionally retightening screws, there is no periodic maintenance recommended for your welder.

## TROUBLESHOOTING

The following TROUBLESHOOTING information is provided as a guide to help resolve some of the more common problems that could be encountered. Table 5 is a troubleshooting table provided to help you determine a possible remedy when you are having a problem with your welder. This table does not provide all possible solutions, only those possibilities considered to likely be common faults. The table consists of a TROUBLE or symptom, a POSSIBLE CAUSE for the symptom, and a POSSIBLE REMEDY for that symptom.

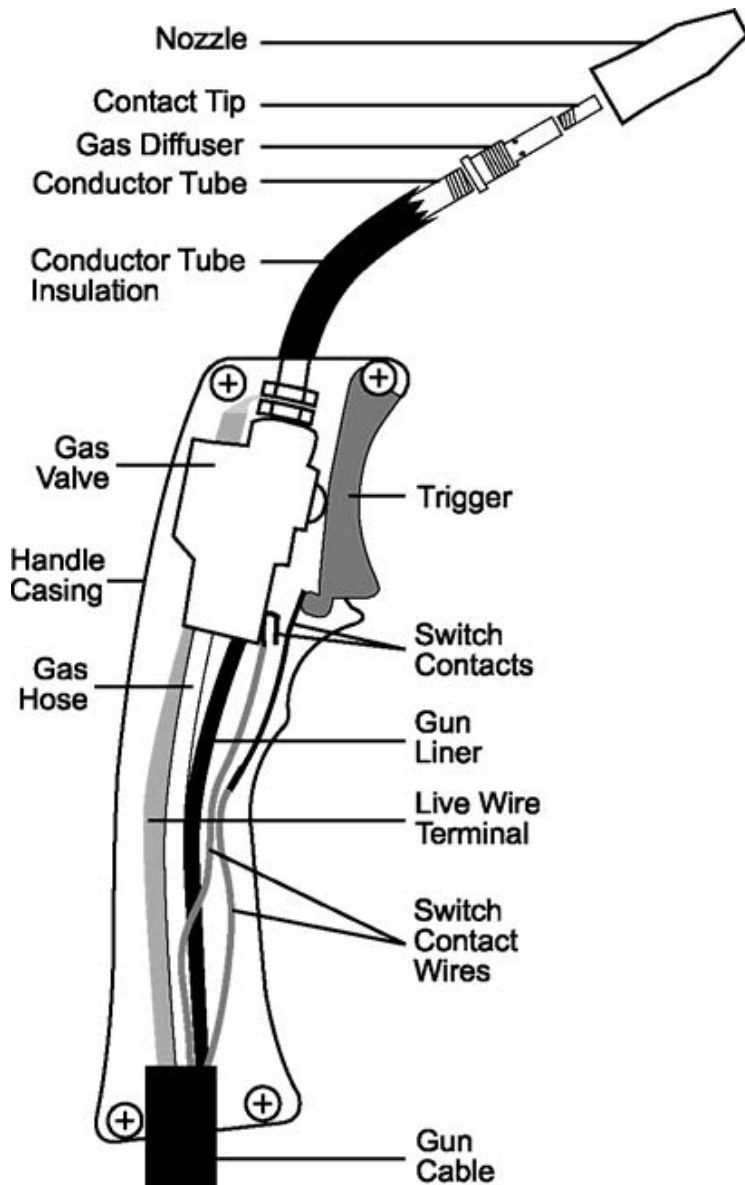
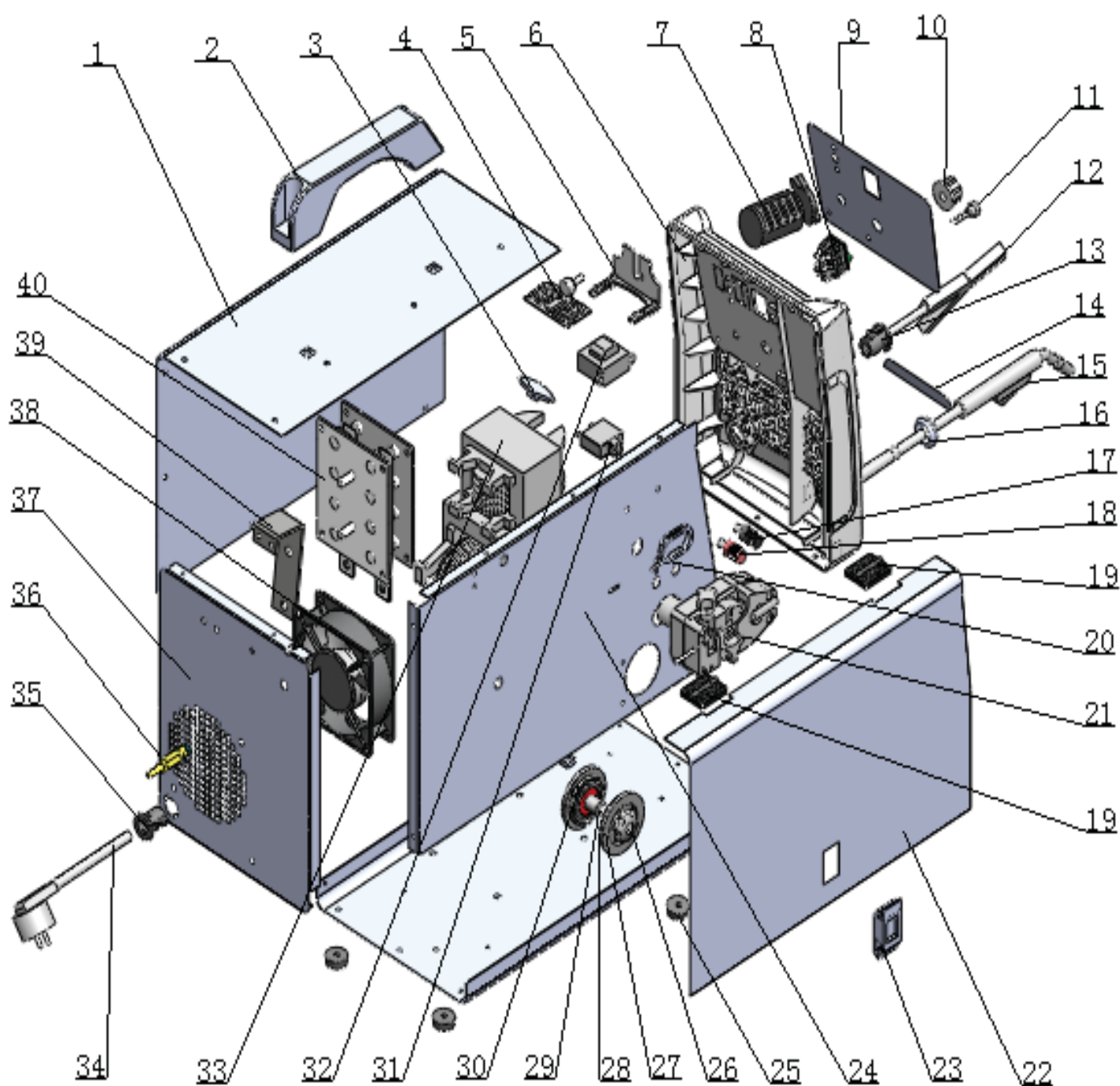


Figure 23. Torch Assembly

## TABLE 5 – TROUBLESHOOTING

TROUBLE	POSSIBLE CAUSE	POSSIBLE REMEDY
Dirty, porous, brittle weld	<ol style="list-style-type: none"> <li>1. Plugged welding nozzle</li> <li>2. No shielding gas</li> <li>3. Wrong type of gas</li> <li>4. Dirty or rusty welding wire</li> </ol>	<ol style="list-style-type: none"> <li>1. Clean or replace nozzle.</li> <li>2. Tank empty, flow restricted or regulator set too low.</li> <li>3. See SELECTING SHIELDING gas section of manual.</li> <li>4. Replace spool of wire.</li> </ol>
Wire feed works but no arc	<ol style="list-style-type: none"> <li>1. Bad ground or loose connection</li> <li>2. Bad connection to torch or faulty torch</li> </ol>	<ol style="list-style-type: none"> <li>1. Check ground and connections. Tighten as necessary.</li> <li>2. Check connection to torch or replace torch</li> </ol>
Arc works but not feeding wire	<ol style="list-style-type: none"> <li>1. Faulty wire speed control assembly</li> <li>2. No tension on drive roller</li> <li>3. Faulty drive motor (RARE!)</li> </ol>	<ol style="list-style-type: none"> <li>1. Replace wire speed control assembly.</li> <li>2. Adjust the drive tension.</li> <li>3. Replace drive motor.</li> </ol>
Nothing works except fan	<ol style="list-style-type: none"> <li>1. Faulty trigger on torch</li> <li>2. Exceeded duty cycle; thermal protector opened</li> <li>3. Faulty transformer (RARE!)</li> </ol>	<ol style="list-style-type: none"> <li>1. Replace torch trigger.</li> <li>2. Let welder cool at least 10 minutes (observe and maintain proper duty cycle.)</li> <li>3. Replace transformer.</li> </ol>
Low output or non-penetrating weld	<ol style="list-style-type: none"> <li>1. Loose connection inside machine</li> <li>2. Too long or improper extension cord</li> <li>3. Wrong type or size wire</li> <li>4. Poor ground connection</li> <li>5. Wrong size contact tip</li> <li>6. Loose torch connection or faulty torch assembly</li> <li>7. Wrong welding polarity set</li> <li>8. Dirty or rusty welding wire</li> </ol>	<ol style="list-style-type: none"> <li>1. Blow inside of machine out with compressed air. Clean and tighten all connections.</li> <li>2. See EXTENSION CORDS section of manual.</li> <li>3. Use correct size wire.</li> <li>4. Reposition clamp and check cable to clamp connection.</li> <li>5. Use correct size contact tip.</li> <li>6. Tighten torch or replace torch.</li> <li>7. Change to proper polarity.</li> <li>8. Replace spool of wire.</li> </ol>
Wire is jamming or "birdnesting" at the drive roller	<ol style="list-style-type: none"> <li>1. Too much tension on drive roller</li> <li>2. Torch liner worn or damaged</li> <li>3. Contact tip is clogged or damaged</li> <li>4. Liner stretched or is too long</li> </ol>	<ol style="list-style-type: none"> <li>1. Adjust drive tension. (See INSTALL THE WELDING WIRE)</li> <li>2. Replace torch liner.</li> <li>3. Replace contact tip.</li> <li>4. Trim liner to proper length.</li> </ol>
Wire burns back to contact tip	<ol style="list-style-type: none"> <li>1. Torch liner worn or damaged</li> <li>2. Liner stretched or is too long</li> <li>3. Wrong size contact tip</li> <li>4. Contact tip is clogged or damaged</li> <li>5. Wire feed speed is too slow</li> </ol>	<ol style="list-style-type: none"> <li>1. Replace torch liner.</li> <li>2. Trim liner to proper length.</li> <li>3. Use correct size contact tip.</li> <li>4. Replace contact tip.</li> <li>5. Increase wire feed speed</li> </ol>
Ground clamp and/or ground cable gets hot	Bad connection from cable to clamp	Tighten connection or replace cable.
Torch nozzle arcs to work surface	Slag buildup inside nozzle or nozzle is shorted	Clean or replace nozzle as needed.

# MIG 190



# MIG WELDER

## spare part list for METAL MAN M190(16/12/2011)

No.	Description	Part number	Qty
1	right panel	1.1.01.02.0336	1
2	handle	2.05.05.970	1
3	heat relay	2.07.36.527	1
4	control PCB	1.1.05.02.0323	1
5	PCB holder	2.05.05.106	1
6	front panel	2.05.05.981	1
7	alternation switch	2.07.80.659	1
8	switch	2.07.80.221	1
9	front panel sticker	2.08.09.066	1
10	potentiometer knob	2.07.11.009	1
11	indicator	1.2.07.02.3104	1
12	grounding cable	1.2.08.02.0235	1
13	cable holder	2.05.05.202	1
14	output sticker	2.08.09.053	1
15	MIG torch	1.2.08.04.0098	1
16	Torch cable holder	2.04.31.109	1
17	connection pole black	2.05.03.114	1
18	connection pole red	2.05.03.115	1
19	hinge	2.05.05.064	2
20	Torch cable holder	2.04.31.105	1
21	wire feeder	2.07.40.357	1
22	left panel	1.1.01.02.0337	1
23	door latch	2.08.07.803	1
24	middle vertical board	1.1.01.03.1276	1
25	feet	2.05.05.016	4
26	nut	2.05.05.307	1
27	spool spring	2.06.29.037	1
28	spool header	2.05.05.306	1
29	spool holder bolt	2.05.05.308	1
30	spool board	2.05.05.305	1
31	circuit breaker	2.07.80.300	1
32	control transformer	1.2.07.02.3107	1
33	main transformer	1.1.04.01.0495	1
34	power cord	1.2.07.01.2588	1
35	cable holder	2.05.05.203	1
36	gas hose connector	2.20.01.030	1
37	back panel	1.1.01.03.1275	1
38	fan	1.2.07.02.3114	1
39	recitifier holder	1.1.01.03.0714	1
40	recitifier	2.07.37.415	1

# WIRE FEED WELDER MODEL WE6484 WIRING DIAGRAM

